



**XEV**  
BORN FOR CHANGE  
USER MANUAL

Thank you for purchasing XEV new energy vehicle products.

Before using this car for the first time, please read this manual carefully and get familiar with the structure and functions of this car, the operation method and the relevant regulations of our company as soon as possible. The content contained in this manual will help you master the correct way to drive and maintain your vehicle, so that you can fully enjoy driving.

This manual aims to provide users with instructions on the use and maintenance of the vehicle. Please check the purchase contract for the specific configuration of the vehicle you purchased. If you have any questions about this car and this manual, please feel free to contact XEV car service station.

All information and specifications in this book are up to date as of the date of printing. Since the company will continue to modify and improve the vehicle, the equipment and performance of subsequent models will be subject to change without prior notice. Please do not compare the equipment and performance of your purchased vehicle according to the contents of other versions of the manual, and put forward the requirements of supplementary equipment on the grounds of the difference between the two. If you have any questions about the purchased vehicle and this manual, please consult XEV car service station.



Drivers must strictly comply with all laws and regulations relating to automobiles. This manual has been written with due consideration and compliance with relevant laws and regulations, but certain entries may not be in accordance with the latest revised laws and regulations at the time of your purchase.

When you resell your vehicle, please attach this manual to the vehicle so that the next user can obtain the relevant information in the manual. No part of this manual may be reproduced, reproduced or translated without the written consent of the Company, nor may it be disseminated in electronic, mechanical records or in any other form. The company solemnly declares that it reserves all rights and interests stipulated in the copyright law and the right to modify.

**XEV**  
**April 2021**

## Warning text about personal safety or damage to the vehicle

In this manual, you will find information about personal safety or possible damage to your vehicle. When operating the vehicle, you must follow the message in order to avoid personal injury or damage to the vehicle. The following classification methods and warning terms are used for the prompt information in this manual according to the danger level:

 <b>ATTENTION</b>	 <b>WARNING</b>	 <b>DANGEEER</b>
<ul style="list-style-type: none"> <li>• Pay attention to minor hazards. Ignoring this information could result in damage to the vehicle.</li> </ul>	<ul style="list-style-type: none"> <li>• Be alert for moderate risk. Ignoring this information could result in injury.</li> </ul>	<ul style="list-style-type: none"> <li>• Be alert to high levels of danger. Ignoring such information could endanger your life.</li> </ul>

## The security tag used in the picture



This safety sign means "strictly prohibited," "Do not do this," or "This situation is strictly prohibited."

## Asterisk (\*)

The asterisk "\*" that appears after the title or text indicates that the device or feature described is available only in certain models and may not be available in the vehicle you are purchasing.

## Use of Vehicles

When you buy a car, please check whether the technical documents are complete. Please read this manual carefully before using the vehicle.

## Vehicle Warranty

According to the prescribed mileage or time limit, please go to XEV special service station for vehicle maintenance and regular maintenance, otherwise the user will be deemed to give up the right of maintenance automatically. The "User's Manual" and "Warranty Manual" of XEV automobile products specify the agreement between the company and the user on the generation and termination of the rights and obligations in respect of product quality guarantee responsibility and after-sales service. Please be sure to carefully read the "Operation Manual" and "Warranty Manual" before using our products. If you do not properly use, maintain, repair the product or refit, adjust or disassemble the vehicle according to the requirements of this manual, you will lose the right to claim for compensation, and any warranty application will be rejected by XEV automobile special service station.

Users are not allowed to modify, adjust or disassemble the vehicle at will. Modification, adjustment or disassembly of the vehicle may affect the performance of the vehicle, especially the safety and durability, or even violate national laws. Any malfunction or performance degradation caused by modification, adjustment or disassembly of the vehicle will not be covered by our warranty.

When replacing the parts of the vehicle, please use the genuine XEV parts to ensure the quality of maintenance and to prevent potential safety risks or damage to the vehicle caused by the use of fake and inferior parts. Failure of the vehicle due to the use of non-xev genuine parts will not be covered by our warranty.

After reading this manual carefully, if you still have any questions, you can go to XEV car special service station or call XEV car customer service center for consultation. Free consultation hotline: 000000 we will provide you with warm and perfect service.



## Location of vehicle identification Number

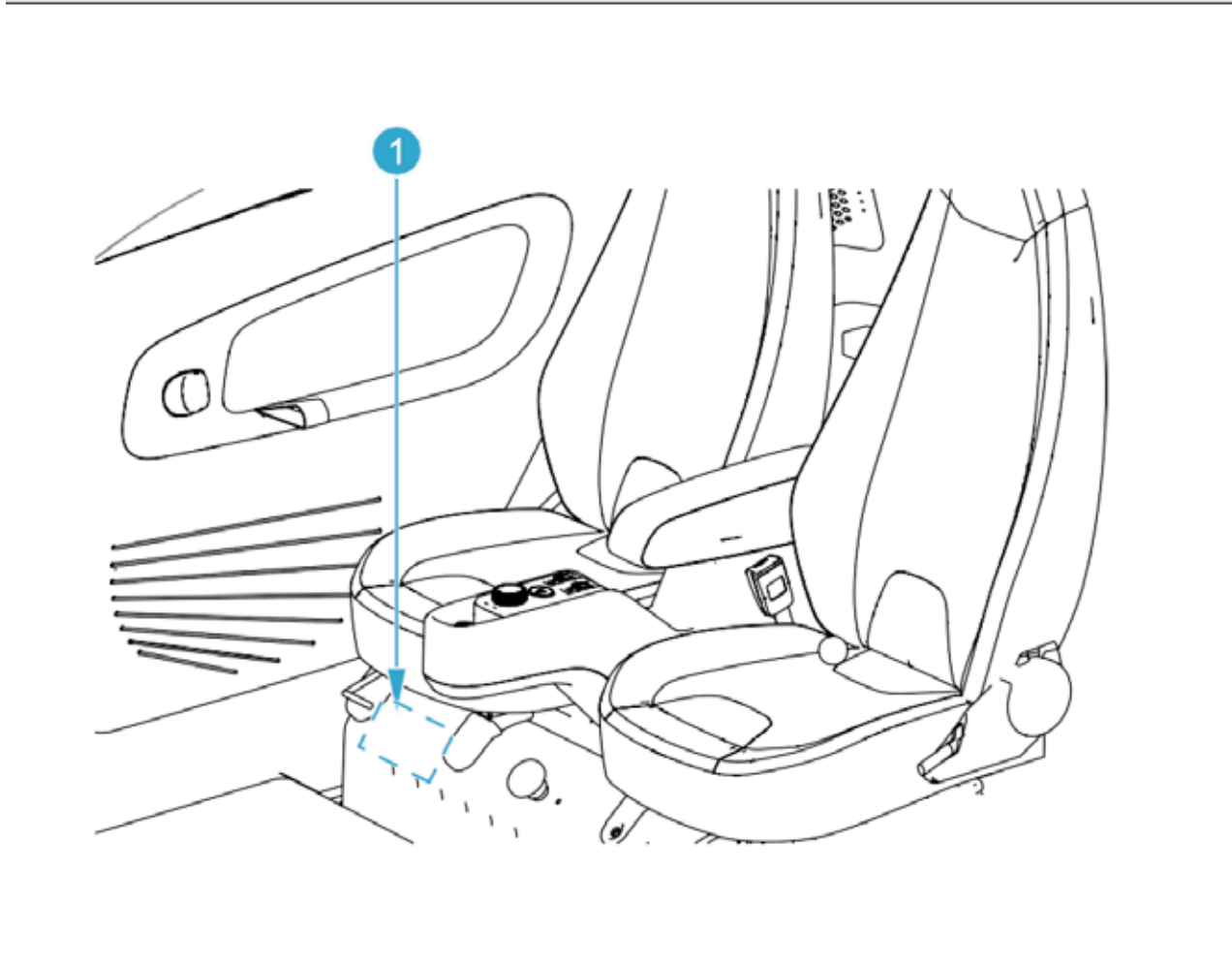

The Vehicle Identification Number (VIN) is the legal identification of a vehicle and is used for registration of the owner. The vehicle identification code (VIN) is located on the vehicle as follows:

**1 Engraved on the sheet metal under the passenger seat**

### Composition and content of vehicle identification number

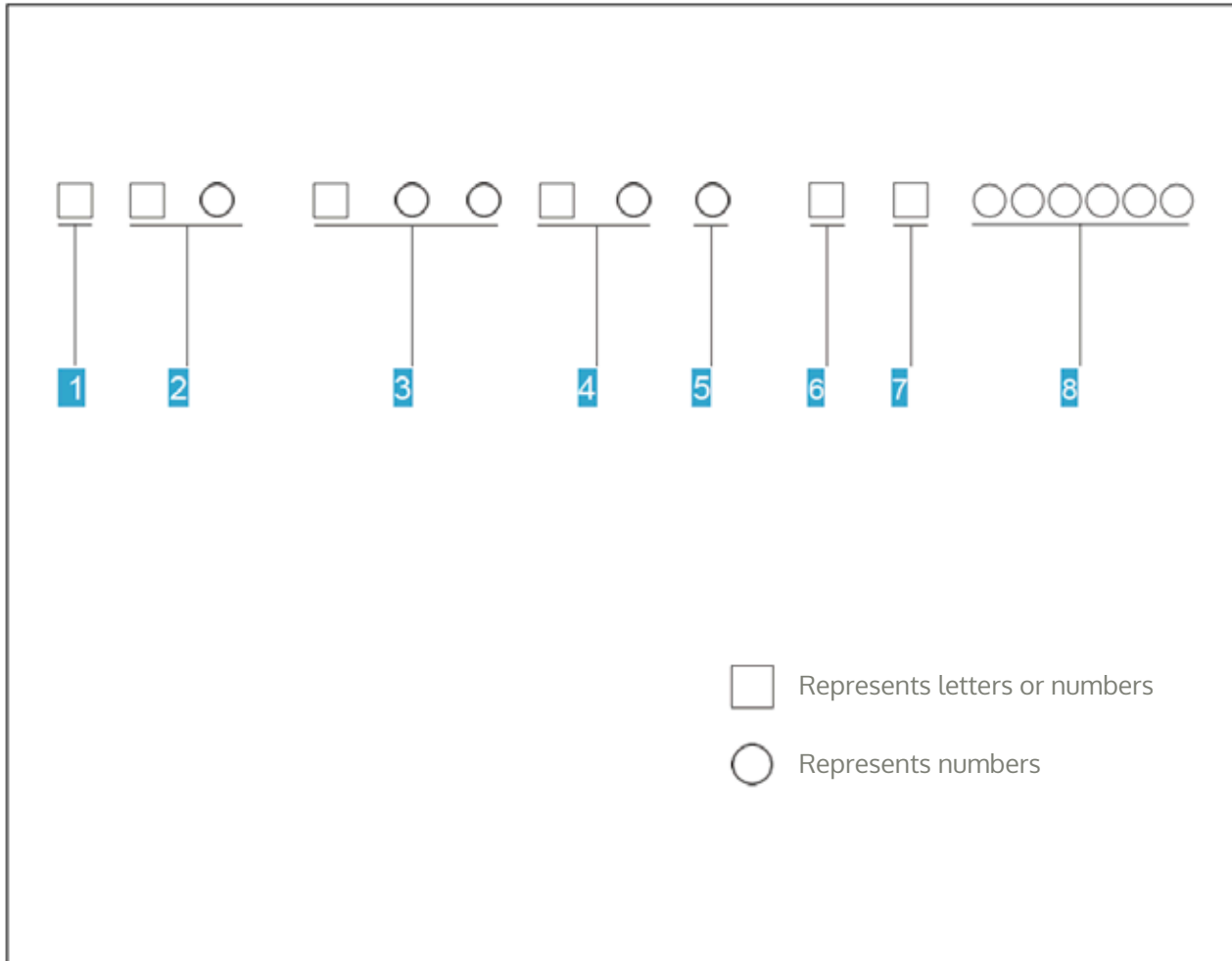

The vehicle identification number (VIN number) consists of 17 characters.

1. country
2. manufacturer
3. vehicle model
4. vehicle version
5. vehicle variety
6. year
7. assembly plant
8. sequence No.

## Vehicle nameplate



**LABEL-TIRE PRESSURE**  
at the car door lock catch

**COLD MEDIA LABEL**  
Above the front bumper

## Manufacturer's nameplate

The manufacturer's nameplate is pasted on the right side of the front coaming.  
The vehicle identification code is marked on the manufacturer's nameplate.

## High voltage system

There are two types of voltage in the vehicle's high voltage system, AC and DC, which are very dangerous and can cause serious injuries such as burns, electric shock and even death. In case of emergency, if conditions permit, you can press the maintenance power-off switch under the console.

## High voltage warning label

Surface of power control unit, surface of driving motor, surface of electric air conditioner compressor, surface of charging machine, surface of power battery, surface of high voltage wiring harness, charging port cover.

### DANGER

- Do not touch high-voltage cables and their connectors.
- The parts with the orange label are all parts of the high voltage system. The warning label of the high voltage system is affixed on these parts. Please comply with the content of the label.
- Any parts in the system, such as slow charging interface device, power battery box, air conditioning compressor, drive motor, vehicle on board charger, etc.

## Maintenance power-off switch

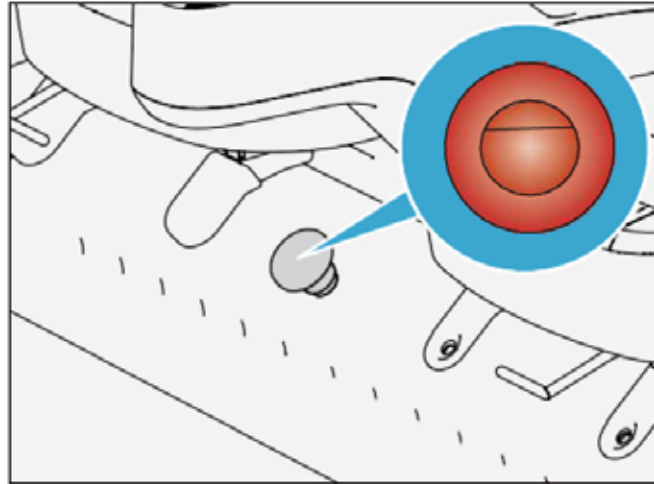

### WARNING

- Do not press the maintenance power-off switch when the ignition switch is in the "ON" position, otherwise it will cause electric shock and other conditions.
- When the vehicle is in the state of charging, the maintenance power-off switch shall not be pressed.
- It is strictly prohibited to disassemble the maintenance power-off switch without the company of professional maintenance personnel.
- It is strictly prohibited to use other conductive metals instead of the maintenance power-off switch.
- The power switch must be cut off before the vehicle maintenance. Live operation is strictly prohibited.

In caso di emergenza o manutenzione, premere l'interruttore di emergenza prima di effettuare qualsiasi intervento, in modo da interrompere l'alta tensione ed evitare scosse. È necessario premere l'interruttore di emergenza nelle seguenti circostanze:

- Revisione di tutte le parti dei moduli ad alta tensione
- Revisione di tutte le parti collegate alla batteria di alimentazione
- Revisione di parti che richiedono la rimozione o lo spostamento di componenti ad alta tensione.

**Image indexing**

The information contained in this manual can be listed by picture annotation for easy reference

**1. Charging device**

Vehicle charging method, precautions and other information

**2. Instrument and control devices**

Instrument, car keys, Windows, wipers and other device information

**3. Lighting device**

Vehicle lights, light switches and other device information

**4. Safety device**

Seat belts and other safety devices

**5. Vehicle device**

Seat, rearview mirror, car auxiliary equipment and other device information

**6. Starting and driving**

Starting, driving, driver assistance, etc

**7. Emergency treatment**

Emergency treatment measures such as vehicle failure

**8. Repair and maintenance**

Vehicle maintenance information

**9. Technical information**

Vehicle technical specifications information

**Alphabetical index**

List the information contained in the user manual in sequence for easy reference

## Charging device

<b>Charging</b> .....	14
Charging requirements .....	14
Influence of charging operation on special population .....	14
Precautions for charging .....	15
Charging time .....	17
<b>Charging mode</b> .....	18
Charging case indicator light .....	18
General charging fault diagnosis .....	19
Slow charging mode .....	20

## Instrument and control device

<b>Combined instrument</b> .....	23
Combination instrument view .....	24
Boot screen .....	25
Flamout state interface .....	25
Remaining power (SOC) indication .....	25
Kinetic energy recovery .....	26
Output power .....	26

Speed display .....	26
Driving mileage .....	27
Gear display .....	27
Warning information prompt .....	27
Subtotal mileage display .....	27
Cumulative mileage display .....	27
Indicator light/alarm light .....	28
<b>Key</b> .....	31
Remote key .....	31
<b>Door</b> .....	34
Front door .....	34
Anti-theft alarm function .....	36
Tailgate .....	36
<b>Window</b> .....	38
Power window .....	38
<b>Cabin door</b> .....	39
Wipers .....	40
Front windshield wiper operation .....	40
Scrubber operation .....	41

## Light device

<b>Light distribution view</b>	43
Light distribution view	43
<b>Lights</b>	45
Lampset	45
Passing beam light	45
Driving beam light	45
Overtaking signal	46
Hazards warning light	46
Turning light	47
Brake light	47
Reversing light	47
Front top light	48
Luci diurne	49
Remote control lights off function	49

## Safety devices

<b>Seat belt</b>	51
Use seat belt	52
Seat belt pretensioner	54

## Vehicle device

<b>Seats</b>	56
<b>Rearview mirrors</b>	57
Exterior rearview mirror	57
Interior rearview mirror	58
<b>Internal equipment</b>	59
Door storage bag	59
Dashboard storage bag	59
Console storage box	59
Cupholder	60
Dashboard storage compartment	60
Sunvisor	60
Console USB	61
Dashboard USB	61
Phone holder	61
<b>Air conditioner</b>	62
Introduction to Air Conditioning Panel	62
Functional operation	63
<b>Multimedia display screen</b>	65
Multimedia main interface introduction	65

Boot screen	66
Radio	66
Setting interface	66
Third-party application interface	68
Bluetooth	69
Phone call	69

## Starting and driving

<b>Driving preparation</b>	72
Run-in period	72
Safety check before driving	72
Precautions before driving	73
Correct sitting posture	74
Check the horn	75
<b>Start driving</b>	76
One key start	76
Pedal	77
Gear knob	78
Parking	79

Electric power steering (EPS)	79
Anti-lock braking system(ABS)	79
<b>Parking</b>	81
Parking precautions	81
Emergency stop	81
<b>Driving in special conditions</b>	83
Night driving	83
Long distance driving	83
<b>Driving in special weather</b>	84
Driving in fog	84
Driving in rain	85
Driving in hot weather	86
Driving in cold weather	86



## Emergency treatment

<b>Emergency treatment</b>	89
Hazard warning lamp	89
<b>Incident treatment</b>	90
Vehicle can't start	90
Vehicle trapped	90
<b>Settle by oneself</b>	91
Flat tyre	91
Use of a warning triangle	92
Towing	92
Hual and reflective vest	95
Replace fuse	96
Ispecification for fuse of instrument distribution box	98

## Repair and Maintenance

<b>Regular maintenance</b>	102
Instructions for regular maintenance	102
Self-maintenance instructions	102
<b>Brake fluid</b>	103
<b>Battery, power battery</b>	104
Battery	104
Power battery	105
<b>Tyre</b>	106
Tyre inspection	106
Tyre wear mark	108
Replacement tires	108
The wheel transposition	109
Tyre chain	109
<b>Windshield wipers and scrubbers</b>	110
Windwindow washing liquid, scrubber nozzle	110
Wiper blade	110
<b>Cleaning and vehicle maintenance</b>	111
External vehicle maintenance	111
Internal vehicle maintenance	114

## Technical information

<b>Technical data</b> _____	117
Overall dimensions of vehicle _____	117
Technical parameters of vehicle _____	118
Drive motor, reducer technical parameters _____	121
Power battery technical parameters _____	123
Technical parameters of DC/DC switch _____	124
Technical parameters of on-board charger _____	125
Type and dosage of vehicle filling liquid _____	126
The light bulb information _____	127

lame del tergicristallo P041

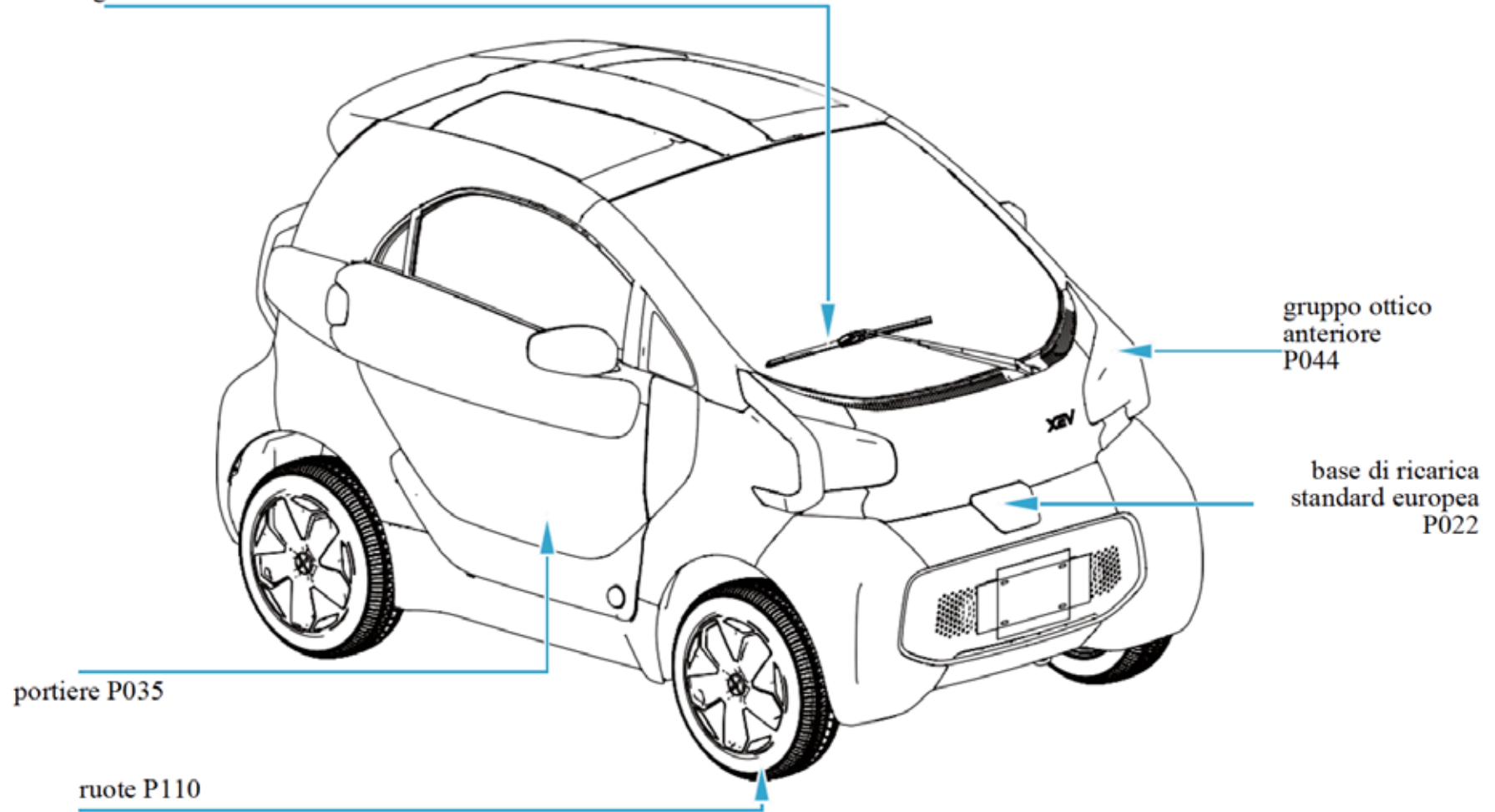

gruppo ottico  
anteriore  
P044

base di ricarica  
standard europea  
P022

portiere P035

ruote P110

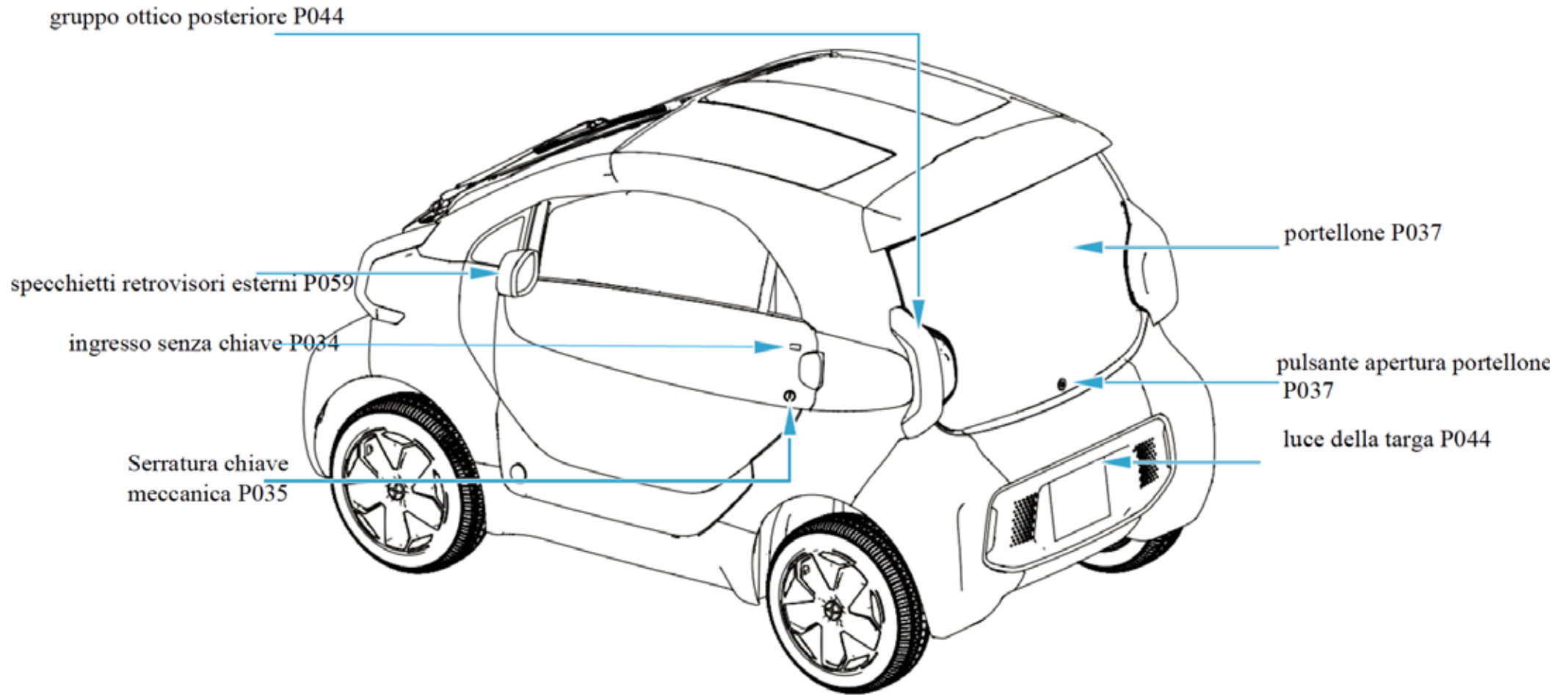

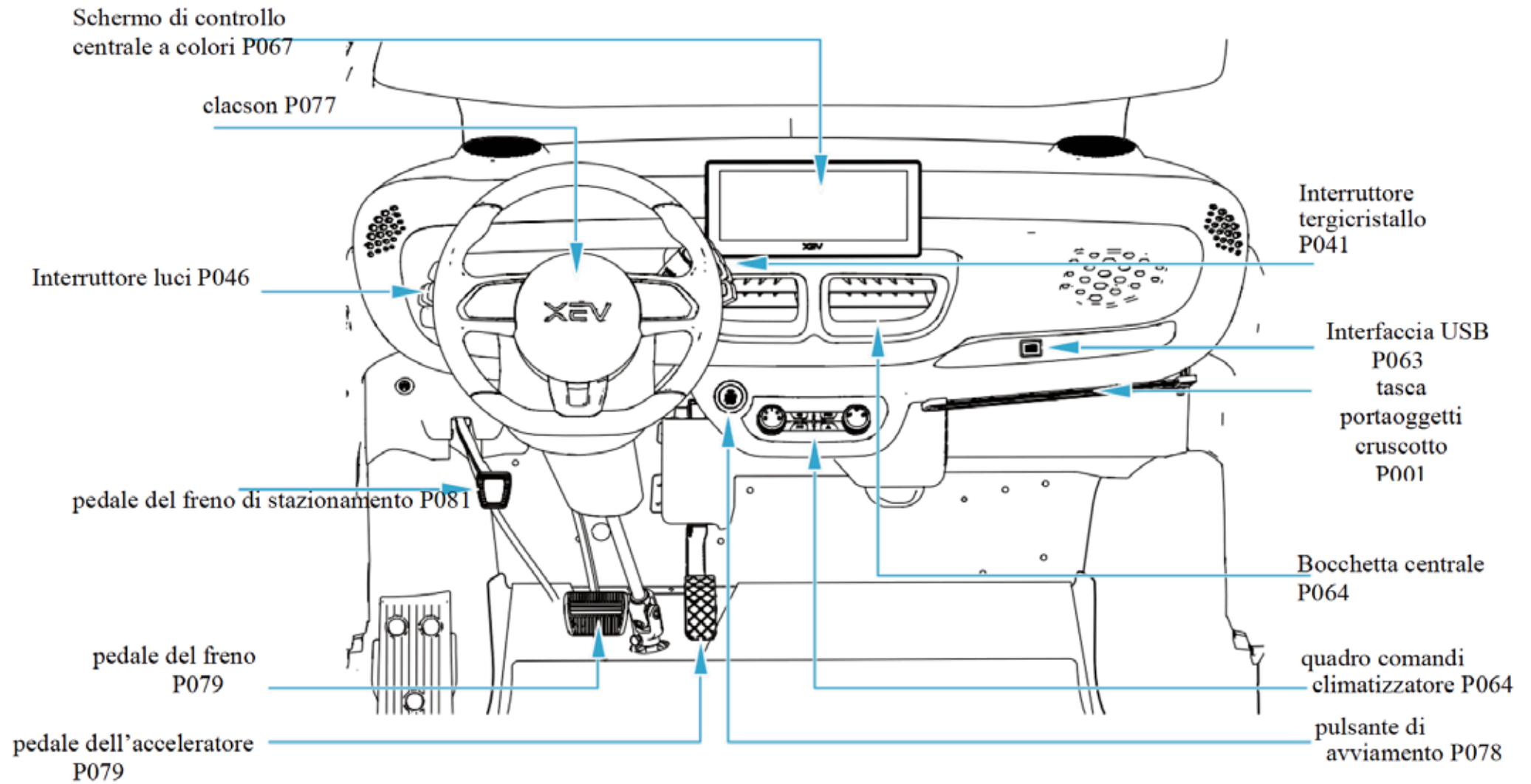

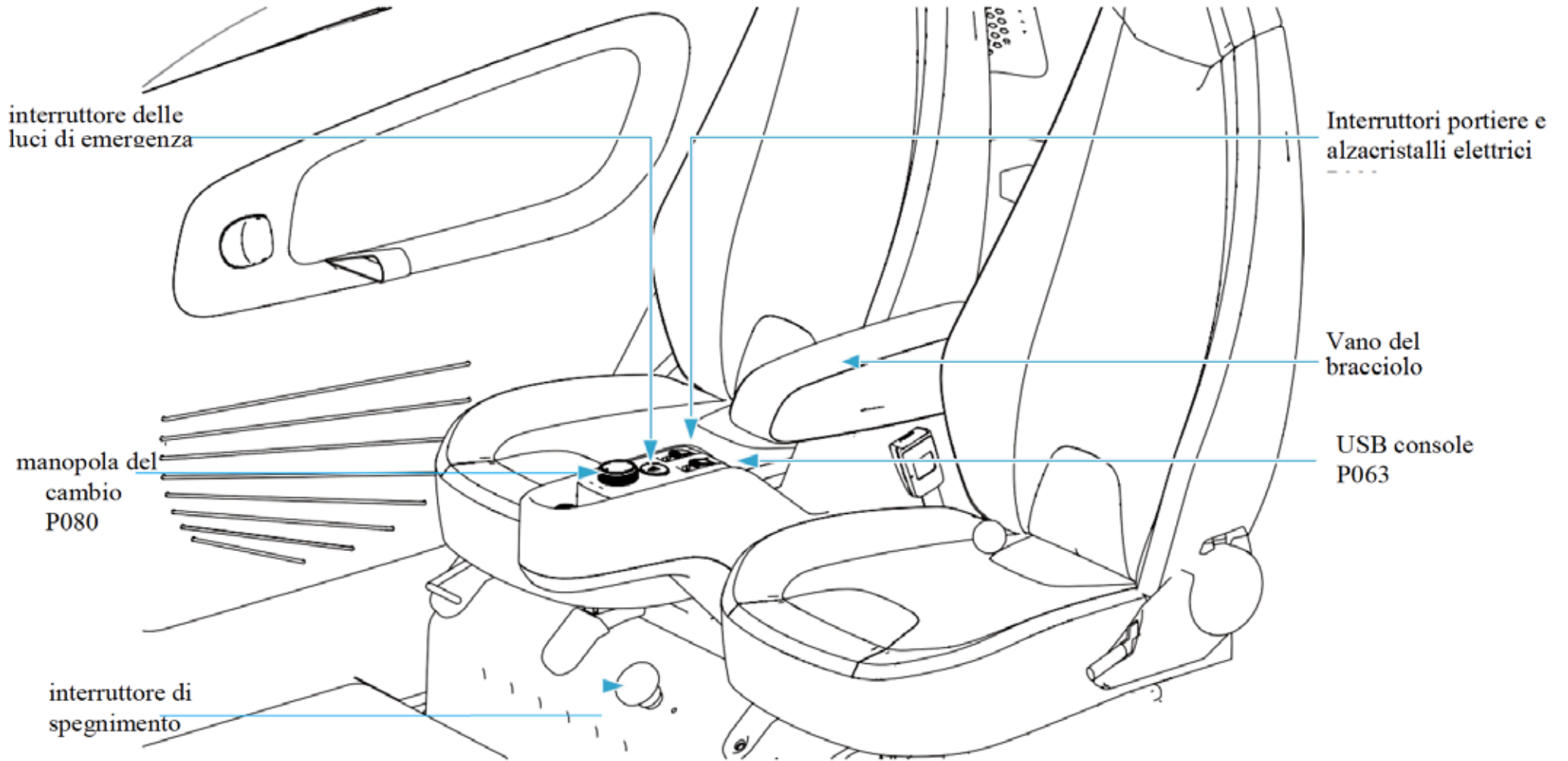

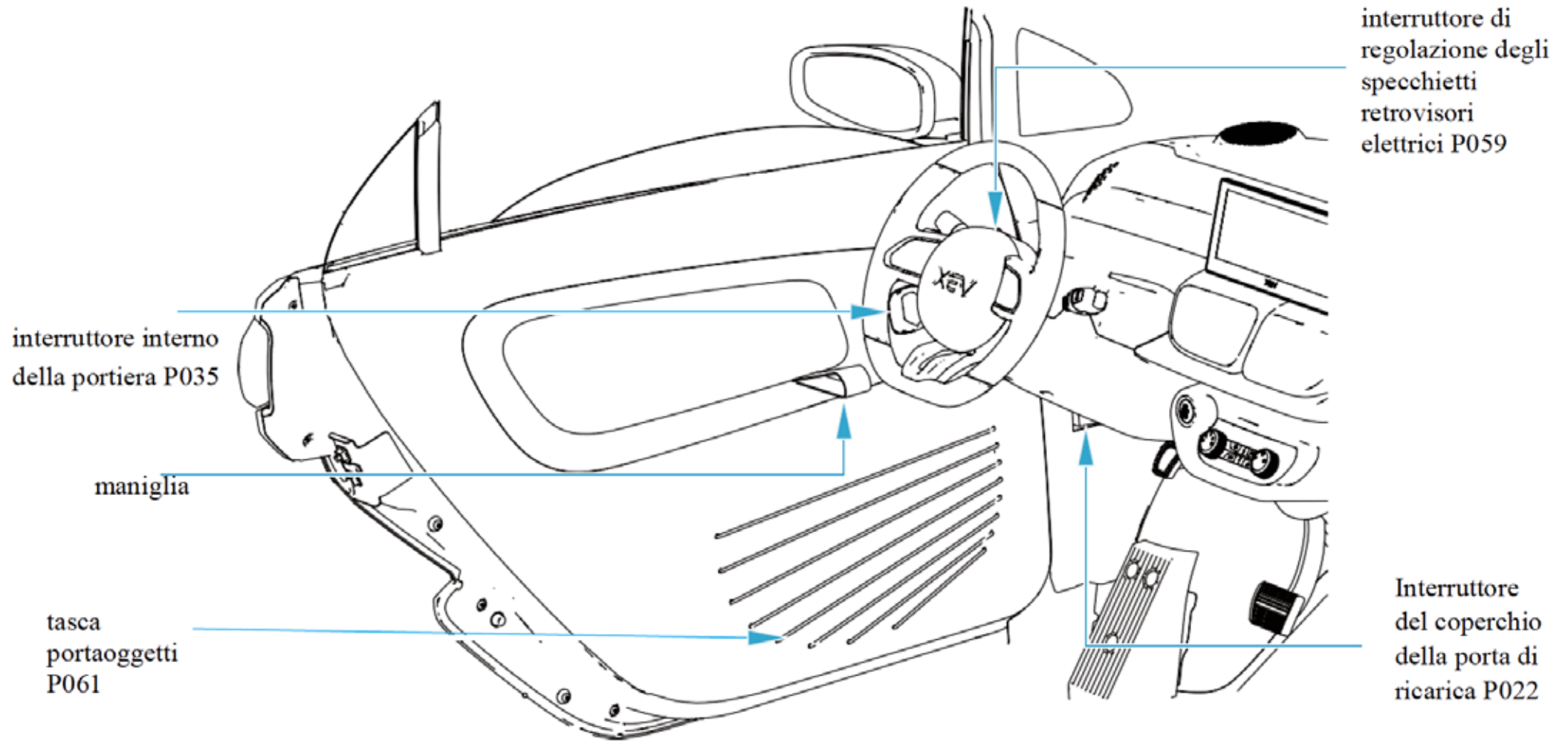



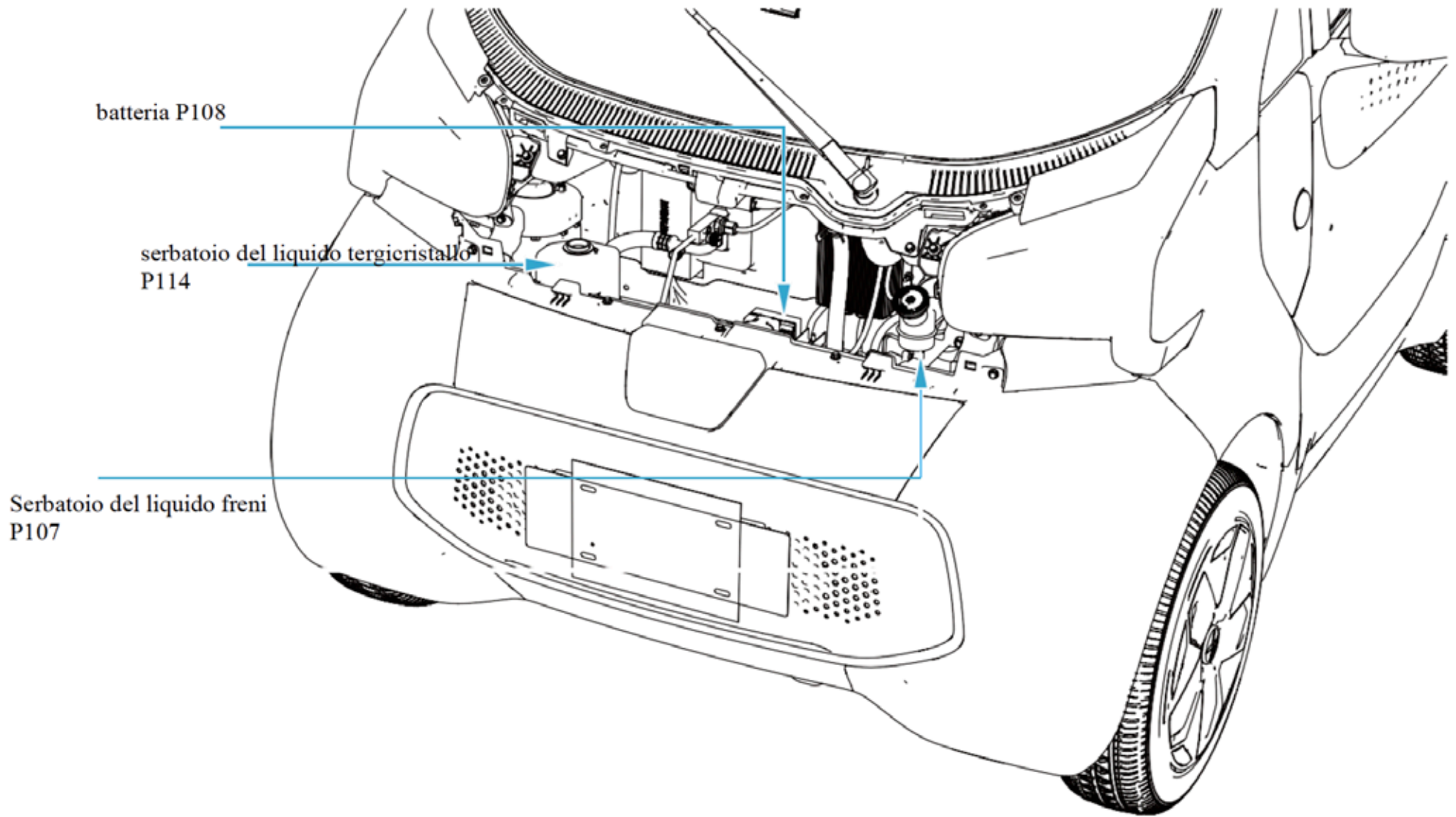





## Charging device

<b>Precautions for charging</b> .....	14
Charging requirements .....	14
Influence of charging operation on special population .....	14
Precautions for charging .....	15
Charging time .....	17
<b>Charging mode</b> .....	18
Charging case indicator light .....	18
General charging fault diagnosis .....	19
Slow charging mode .....	20

### Charging Requirements

- Some modules of the charging equipment may produce electric sparks inside. In order to avoid accidents, please do not charge at gas stations or places with flammable gases or liquids.
- Charging operation time will be affected by the external temperature. Charging time will be prolonged at low temperatures.
- 220V AC voltage fluctuation range in  $\pm 10\%$ .
- Recharge the vehicle with AC slow charge at least once every half a month until the charging current is 0, so that BMS can real-time calibrate the SOC of the battery pack.

 <b>WARNING</b>
<ul style="list-style-type: none"> <li>• Before charging, check whether the body charging interface and charging equipment are in good condition.</li> <li>• When charging, the charging gun is connected to the European standard charging socket of the front bumper of the vehicle and then connected to 220V AC power supply.</li> <li>• Do not start the vehicle during charging.</li> <li>• After charging, disconnect the car front bumper European standard charging socket, then disconnect 220V AC power supply, and cover the body charging port.</li> <li>• In the process of charging operation, it is strictly prohibited for people around to contact the vehicle and power supply equipment.</li> <li>• It can also be charged in rainy days, but attention should be paid to rain protection in the process of plugging and pulling the charging gun. In case of extreme weather such as thunderstorm, it is recommended to stop charging operation.</li> </ul>

### Influence of charging operation on special population

- During rapid charging operations, electromagnetic field interference may occur in the operating area. Users carrying implantable pacemakers or implantable cardiovascular defibrillators are advised to stay away from vehicles while charging.
- Interference with electromagnetic fields may affect the normal function of medical electronic devices. It can lead to injury or death for people carrying implantable pacemakers, implantable cardiovascular defibrillators, etc.
- When the vehicle is not charged, special people can safely ride and drive the vehicle.

### Precautions for charging

In the process of driving, if the battery bar remains 30% (yellow), charge as soon as possible, and 10% (red), charge must be carried out.

In order to prolong the service life of the power battery and ensure driving safety, the power battery should be avoided to run out.

Charging process is divided into large current constant current charging, trickle charging, constant voltage charging, until completion, so near the end of charging, charging current will change, which is normal.

 <b>WARNING</b>
<ul style="list-style-type: none"> <li>• Please choose to charge in a relatively safe environment (e.g. avoid liquid, fire source, etc.).</li> <li>• Before charging, please ensure that there is no water or foreign matter in the vehicle charging port and charging gun port, and there is no damage or influence caused by rust or corrosion of metal terminals.</li> <li>• Please keep your hands dry when connecting the charging plug.</li> <li>• When charging, the ventilation of the charging place must be guaranteed. Charging in a closed and narrow space is strictly prohibited.</li> <li>• After charging, do not disconnect the charging gun with wet hands or while standing in the water, as this may cause electric shock and personal injury.</li> <li>• Please make sure the charging gun is disconnected from the charging port before driving.</li> </ul>

 <b>WARNING</b>
<ul style="list-style-type: none"> <li>• Users who use any electronic medical device (such as an implanted cardiac pacemaker) should check with the manufacturer before using the device to see if the charging will affect the normal operation of the device. Charging may lead to abnormal operation of the device and cause personal injury.</li> <li>• If you find that the car is emitting an unusual odor or smoke that does not use any electronic medical device (such as an implanted heart) while charging, stop charging immediately.</li> </ul>

**In order to avoid serious personal injury, the following precautions should be taken when the vehicle is charging:**

- Do not touch the charging port or the metal terminals in the charging gun.
- When there is lightning, do not charge the vehicle or touch the vehicle. Lightning may damage the charging equipment and cause personal injury.

**In order to avoid damage to the charging equipment:**

- Do not close the charging port door with the charging port dust cover open.
- Do not pull or twist the charging cable.
- Do not expose the charging device to impact.
- Do not use the charging equipment in the environment where the temperature is higher than 55 or lower than -20.
- Do not place the charging device near a heater or other heat source.

**⚠ ATTENTION**

- Home AC charging is carried out using the vehicle equipped with the AC charging connection device. 220V 50Hz AC special circuit and power socket are recommended. The purpose of the special circuit is to avoid the damage of the line or the trip of the line due to the high power when charging the power battery. If the special circuit is not used, the normal work of other equipment on the line may be affected. If a dedicated line is no longer usable, it should be installed by a professional electrician. Charging pile or DC quick charging machine can also be used to charge the car (with quick charging function of the configuration car).
- When the power is supplied again after the power is cut off from the external grid, the charger cannot be awakened and the charging gun needs to be replugged to charge.

**⚠ ATTENTION**

- Do not stay in the car while charging.
- The starting switch shall not be in the position of "ACC" or "ON" for a long time during charging.
- When the power battery is fully charged, the system will automatically stop charging.
- Before starting the vehicle, make sure the charging gun is disconnected, the dust cover of the charging port and the charging port door are closed. Charging port dust cover is not closed, water or foreign substances may enter the charging port terminals, affecting the normal use.

### Initial charge

When the power battery is used for the first time, it must be fully charged (SOC is 100%, charging current is 0).

- During the use of the vehicle, the power battery needs to be fully charged once every 1 month (SOC is 100% and the charging current is 0).
- The power battery needs to be fully charged once every three months when the vehicle is not in use (SOC is 100% and the charging current is 0).
- Operating temperature range of power battery: 0 ~ 45 when charging; Discharge at -10 ~ 50.
- The nominal voltage of the power battery is 76.8V; The maximum charging limit voltage is 87.6V.

### Charging time

The charging time of high-voltage power battery is related to many factors, such as current electric quantity, charging mode, ambient temperature, power supply device and so on. With slow charging, depending on the battery pack, it takes about 5~7 hours to fully charge.

Please contact XEV new energy vehicle authorization service station

### Slow charging time

At normal temperature, it takes about 5~7h from alarm state (low alarm of remaining electric quantity) to full electric quantity (full display of remaining electric quantity).

### ⚠ ATTENTION

- At low temperature, the required charging time will be extended; It is recommended to charge at the ambient temperature of 0~45.
- Power supply unit output power is insufficient, the required charging time will be extended.
- After the vehicle is idle for no more than one month, balanced charging shall be carried out before the first use. The charging time shall be appropriately extended for 1~2h on the basis of 7h to complete the charging balance.

Charging case indicator light

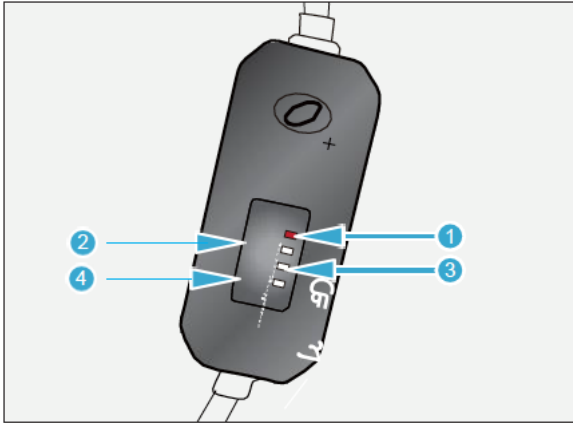

There are 4 indicator lights on the charging case, respectively:

- 1 Power light
- 2 Connection light
- 3 Charging indicator
- 4 Connection/charge indicator Fault indicator

Indicator light and working state of cable protection box are designed in accordance with the following table (fault alarm mechanism):

control box state	power	connection	charging	fault
power connection	constant on	on(1s)	on(1s)	on(1s)
undergrounded protection	constant on	constant on	off	off
vehicle connection	constant on	constant on	off	off
normal charging	constant on	constant on	lampeggio	off
end of charging	constant on	constant on	off	off
current fault	constant on	off	off	flicker (once)
overvoltage fault	constant on	off	off	flicker (twice)
undervoltage fault	constant on	off	off	flicker (three times)
other defaults	constant on	off	off	constant on

## General charging fault diagnosis

In normal use, plug 16A into the power socket first, and the control box will detect the grounding wire of the charging socket first. If no grounding wire is detected, the power lamp and the connecting light will be on and the charging is prohibited. If the ground line is detected, the control box self-check the four indicator lights on (bright 1S), the power indicator lights on; After the charging gun is successfully connected to the vehicle socket, the indicator light of the connection of the control box will be on. After the charging machine at the vehicle end self-checks without failure, the control box on the cable is allowed to charge. The closing relay of the control box starts charging and the charging indicator light flashes at the same time. After charging, the charging indicator is off, and only the power supply and connection indicator lights on. In the process of charging, please pull out the power plug first and then pull out the charging gun to avoid damage to the plug and power socket.

Protection function	
Output over-current protection	Current greater than 13A open protection, disconnect output
Residual current protection	line L, line N current imbalance, more than 30mA protection, disconnect the output
Input undervoltage protection	Input voltage below $176V \pm 4V$ , start protection, disconnect output
Input overvoltage protection	Input voltage below $264V \pm 4V$ , start protection, disconnect output
Charge complete protection	When the charging current is less than 1A for a long time, the charging will be considered complete, the protection will be activated and the output will be disconnected
Over-temperature protection	75°C, inside temperature, disconnected output

Slow charging mode

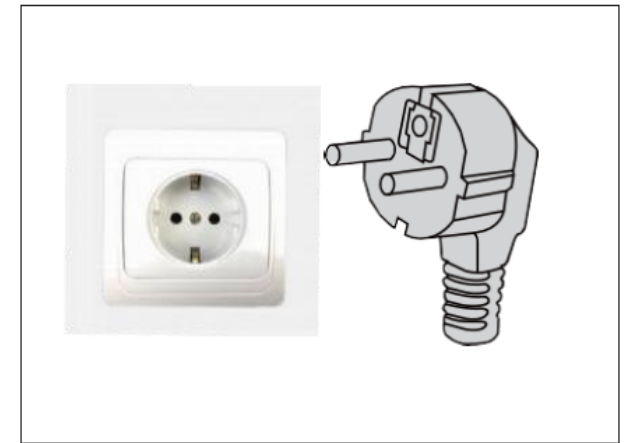
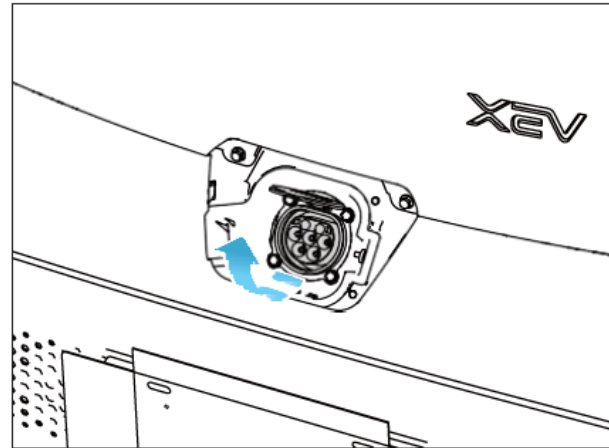
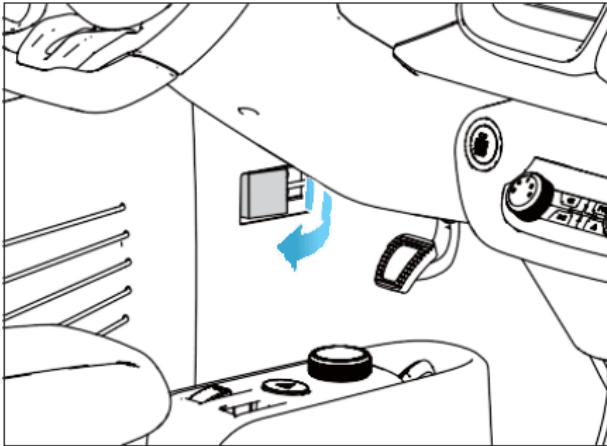

Before charging, ensure that the starting switch is in the state of "OFF". Step down the parking brake pedal, and the power OFF switch is in the state of pulling and switching on.

Pull the slow charging port opening handle located at the lower protective plate of pillar A at the lower left of the instrument panel from the car, and open the slow charging port cover.

Pull the lock tongue of the charging port dust cover, open the charging port dust cover, and connect the charging gun to carry out charging operation.

Insert the European standard charging plug into the standard socket. The power indicator is always on. Insert the AC charging gun into the vehicle interface - AC vehicle charging socket

**⚠ ATTENTION**

- In order to facilitate the operation and safe use, it is recommended that the height of the power supply socket should not be more than 30cm from the ground, and the charging box should be fixed to avoid the force on the plug, otherwise it is easy to cause the product to fall and damage.
- This product is an electronic product, should not be placed in direct sunlight or wet place to use.

**⚠ ATTENTION**

- After the plug is completed, if the connection is normal, the online control box will start automatically and the on-board charger will start charging the vehicle battery.
- After the battery is fully charged, the charging indicator light of the on-line control box is always on.



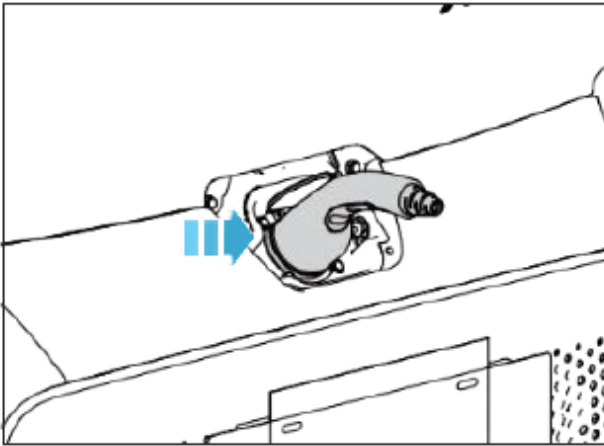

When the operation is stopped, first pull out the European standard plug on the power side, and then pull out the charging gun.

**⚠ PERICOLO**

- The circuit breaker must be installed on the power side, and the power socket should strictly use the required standard socket, and the current carrying capacity is sufficient. The front-end wiring of the socket should meet the wiring requirements of the standard European standard. Use reliable grounding, otherwise there is danger of electric shock.
- In the process of charging, do not force out the AC vehicle charging gun, otherwise it is easy to cause damage and danger.

**Instrument display when slow charging:**

1. Charge connection on indicator light on assembly instrument
2. When charging, the current electric quantity percentage is dynamically displayed as follows

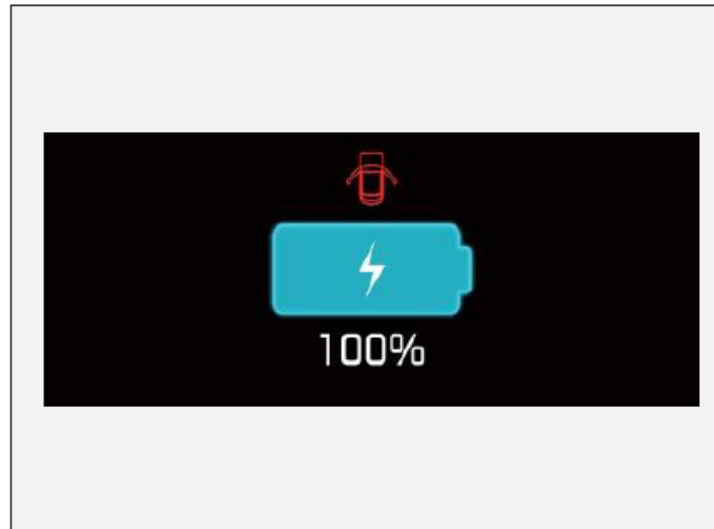

## Instrument and control devices

<b>7inch hardware introduction</b> _____	23	<b>Indicator light/alarm light</b> _____	28
Combination instrument view _____	24	<b>Key</b> _____	31
Boot screen _____	25	Remote key _____	31
Flamout state interface _____	25	<b>Door</b> _____	34
Remaining power (SOC) indication _____	25	Front door _____	34
Kinetic energy recovery _____	26	Anti-theft alarm function _____	36
Output power _____	26	Tailgate _____	36
Speed display _____	26	<b>Window</b> _____	38
Driving mileage _____	27	Power window _____	38
Gear display _____	27	<b>Cabin door</b> _____	39
Warning information prompt _____	27	Wipers _____	40
Subtotal mileage display _____	27	Front windshield wiper operation _____	40
Cumulative mileage display _____	27	Scrubber operation _____	41

7inch hardware introduction

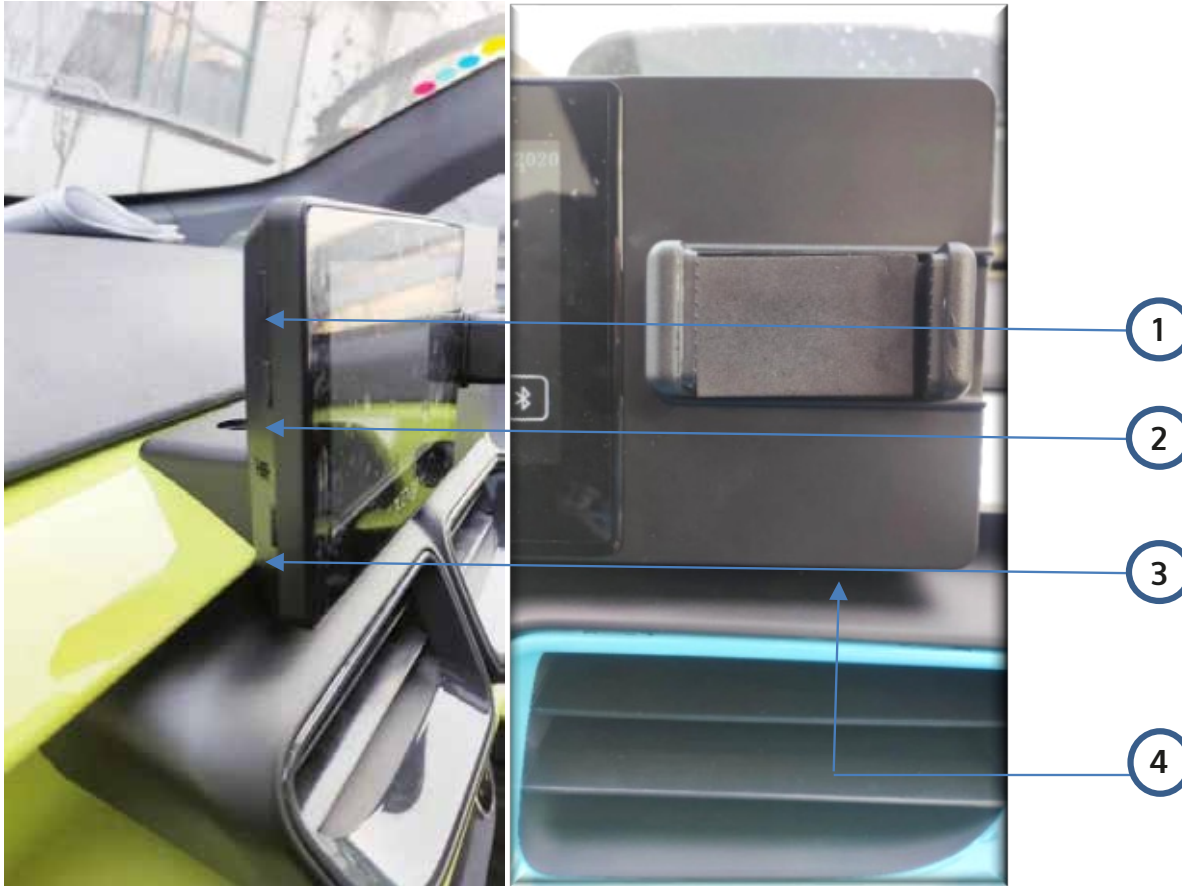

1. Up button	p. 23
2. Down button	p. 23
3. Function button	p.. 23
4. Phone frame	p. 23

Combination instrument view

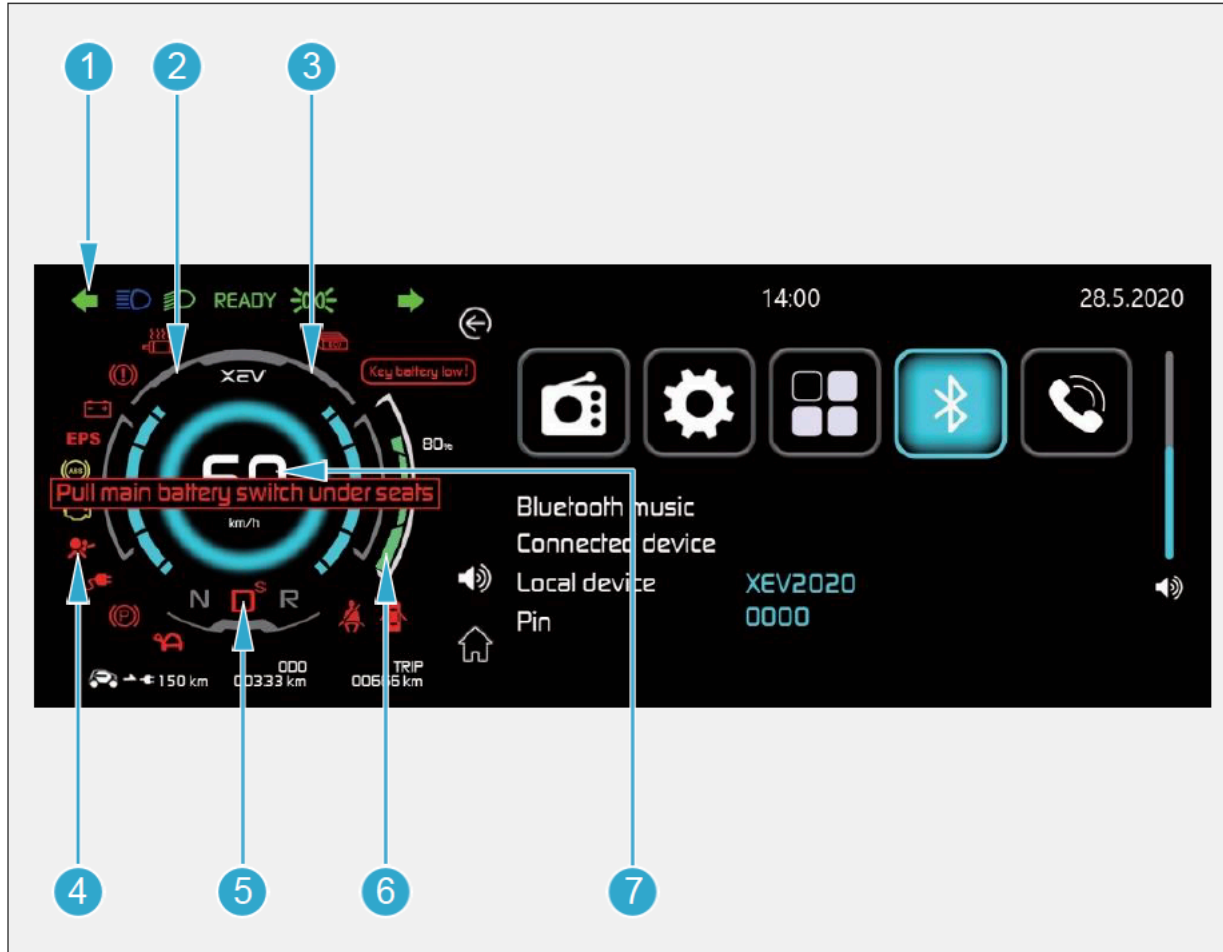

1. Indicator light	p. 28
2. Output power	p. 25
3. Kinetic energy recovery	p. 25
4. Warning light	p. 28
5. Gear indication	p. 26
6. Battery residual capacity	p. 23
7. Vehicle speed display	p. 26



Boot screen indication

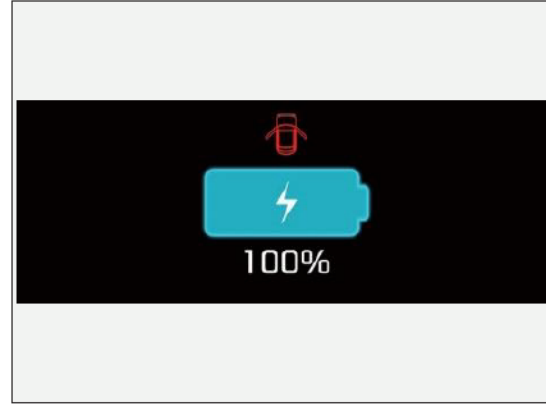

Boot animation, voice welcome "welcome to XEV".

Flameout state interface



In charging, the icon "  "dynamic display of the current power percentage the door is not closed to show the status icon "  "

After the door is completely closed, the screen goes off and the instrument enters the sleep state within 20 seconds.

Remaining power (SOC)



The remaining 10% of the battery bar is red, 20% is orange, 30% is yellow, and the rest are green.

The right side shows the percentage of battery bar synchronou

Charging device	Instrument & control devices	Lighting device	Safety device	Vehicle device	Starting & driving	Emergency treatment	Repair & maintenance	Technical information
-----------------	------------------------------	-----------------	---------------	----------------	--------------------	---------------------	----------------------	-----------------------

Kinetic energy recovery



Vehicle speed display



Output power



Indicating kinetic energy recovery

<b>WARNING</b>
<ul style="list-style-type: none"> <li>Excessive drive motor temperature may cause serious damage to the drive motor. When this happens, pull over safely and turn off the starting switch immediately, and contact the XEV new energy authorized service station for maintenance as soon as possible.</li> </ul>

Indicating output power

<b>ATTENTION</b>
<ul style="list-style-type: none"> <li>If the driving motor temperature is too high, the vehicle will limit the torque output to ensure that the motor temperature does not rise.</li> </ul>

Speed display is used to display the current vehicle speed. It is digitally displayed on a multi-function display screen in km/h (km/ hour).



Driving mileage



Displays the current mileage available.

Gear display



Displays the current gear knob position (R, N, D) when the start switch is in "ACC" or "ON" state.

Warning information prompt



Display the current warning information

Subtotal mileage display



Subtotal mileage display is used to display the mileage traveled since the odometer was last cleared to zero. Display range is 0~999 99km







Accumulated mileage display



Used to display the total mileage (ODO) traveled by the vehicle. The display range is 0~999 99km.









Charging device	Instrument & control devices	Lighting device	Safety device	Vehicle device	Starting & driving	Emergency treatment	Repair & maintenance	Technical information
-----------------	------------------------------	-----------------	---------------	----------------	--------------------	---------------------	----------------------	-----------------------

### Indicator light / warning light

Indicator light		State
	Position light	This light is on when the position light and passing beam light are turned on.
	Driving beam light	Turn on the driving beam light, and turn this light on.
	Parking brake working indication	This lamp is on when parking is applied.
	Indicator lamp left turn	This light flashes when the left turn signal is turned on.
	Indicator lamp right turn	The light flashes when the right turn signal is turned on.
	The charging cable is connected to the indicator	This indicator light is on when the charging cable is connected.
<b>READY</b>	Vehicle readiness indication	When the vehicle is in the state of running readiness, the Ready indicator light is lit, accompanied by a "drip" prompt tone.
	Danger warning indicator light	The hazard warning light flashes when turned on.



### Indicator light / warning light

Warning light		State
	Claudication instructions	When the vehicle is in the state of power-down driving, the instrument lights up the power-down driving indicator.
	Anti-lock braking system (ABS) failure warning light	This lamp is on when the anti-lock braking system fails. When the start switch is in the "ON" position, the light will be ON for 3 seconds for self-check and then off. If the light is still ON after the self-check is completed, you are advised to contact the XEV service station for maintenance.
	Brake level alarm lamp	When the brake liquid level is low, the lamp is on.
	Warning light for the driver's seat belt not fastened	When the start switch is in the "ON" gear, if the driver's safety belt is not fastened, the light will always flash. When the speed is greater than 25km/h, the buzzer will alarm (100s), and the light will not be extinguished until the driver is fastened with the safety belt.
	Battery charging fault warning light	If the light is on when the vehicle starts, please shut down and turn off all electrical appliances on the vehicle to check whether the vehicle is in trouble. If necessary, please contact XEV special service station for maintenance.
	Airbag failure warning light	When the start switch is in the "ON" position, the lamp will be lit for 3 seconds for self-check and then extinguished. If the light does not go off or is always on after the completion of the vehicle self-inspection, the warning light is always on or flashing during the vehicle driving, indicating that the warning light or the airbag system is out of order. It is recommended that you contact XEV special service station for maintenance. (For vehicles with airbags).
	Warning light for door not closed	When any door or back door of the vehicle is opened, the light will be lit to remind the driver that the door is open or not closed well.
	Motor overheating indicator light	When the temperature of the motor is too high, the light will turn on.

Indicator light / warning light

Spia di avvertimento		Stato
<b>OBD</b>	System failure alarm light	When the start switch is in the state of "ON", the OBD light will be ON when the system self-check vehicle has a fault of above level 3.
<b>EPS</b>	EPS (electric power system) fault alarm lamp	This lamp is on when the electric power system fails. It is recommended that you contact XEV special service station for maintenance.

**ATTENTION**

- If the following fault warning lights appear on the instrument during the operation of the vehicle, please move to a safe position and call the rescue phone.

Examples of failure warning lights: **OBD** **EPS**

## Remote key

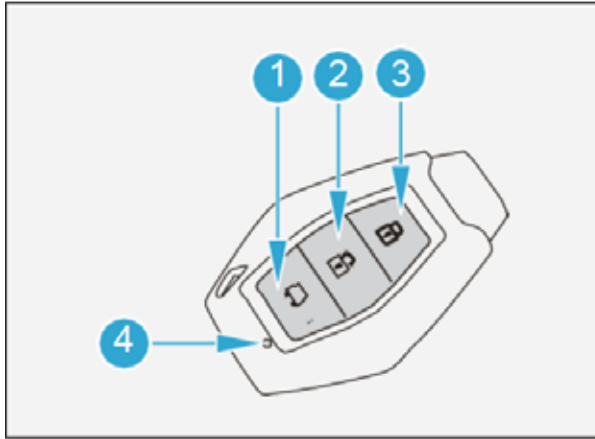

The remote key unlocks or locks the door remotely and searches the vehicle

- 1 Remote control search button
- 2 Remote unlock button
- 3 Remote locking key
- 4 Work indicating light

Unlock and lock doors --> page 32

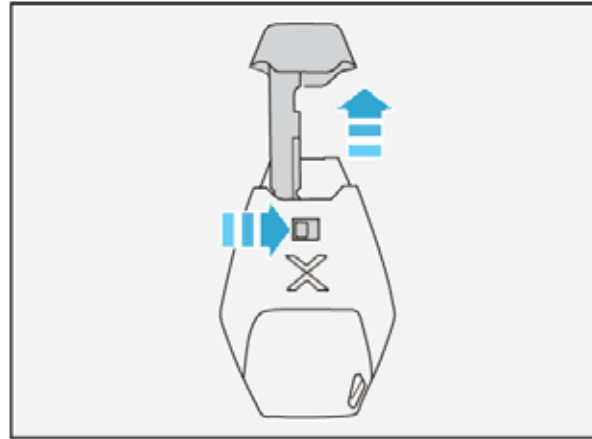

## Take out the mechanical key

Push the locking mechanism to the right and pull the pull ring to remove the mechanical key. The mechanical key is used to open the front door. Be sure to put it back when not in use.

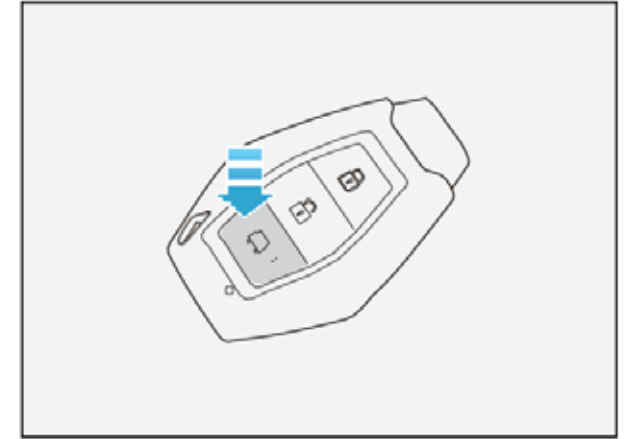

## Vehicle search

Press the search button of the remote control to execute the search function. At this time, the turn signal flashes 15 times and the horn rings 3 times. If the key unlock or lock remote control signal is received during the period, the flashing will stop.

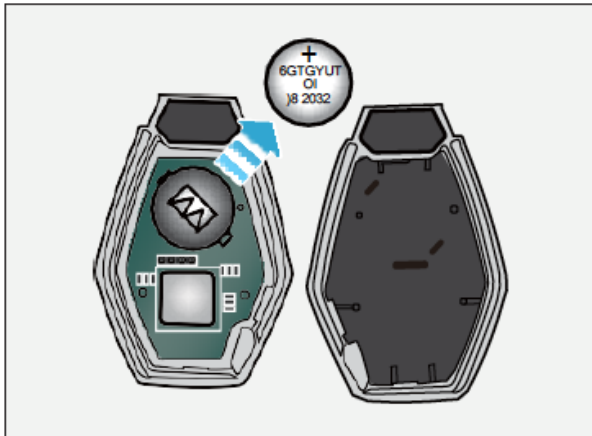

### Replace the battery of the remote control key

- Take out the mechanical key
- Use a straight screwdriver to pry open the back cover of the key carefully. Be careful not to drop the circuit board inside.
- Use a straight screwdriver to carefully push the battery out, not touching the circuit board.
- Load the new battery, pay attention to the position of the positive and negative poles (" + "pole facing up).
- Close the key back cover and insert the mechanical key.

### ⚠ ATTENTION

- The specifications of the new battery must be the same as the original battery.
- Battery specification: CR2032.
- Used batteries must be disposed of in accordance with environmental requirements.
- Please keep the spare key in a safe place, not in the car.
- The remote key is equipped with a sophisticated circuit board and must be protected from shock, water, moisture, solvents, waxes and scrubbing agents, and high temperatures.

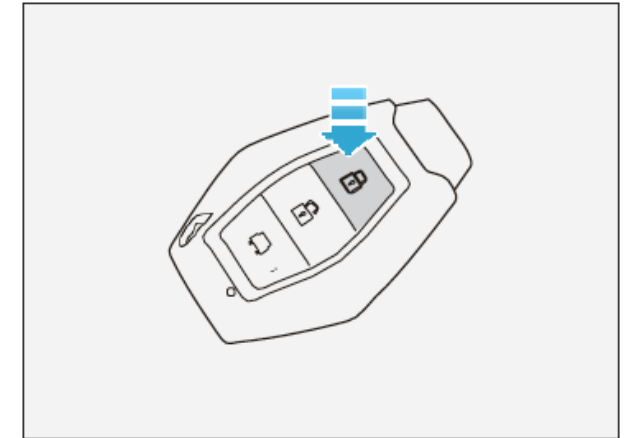

### Remote control key to lock and unlock the door

If all doors are closed, all doors are locked, left and right turn signal flashes once, the vehicle enters the fortified state.

If any door is not closed well, the turn signal flashes 4 times with a cycle of 840ms, 50% duty ratio, and the horn sounds once to prompt the door to be closed, and the door lock does not move.

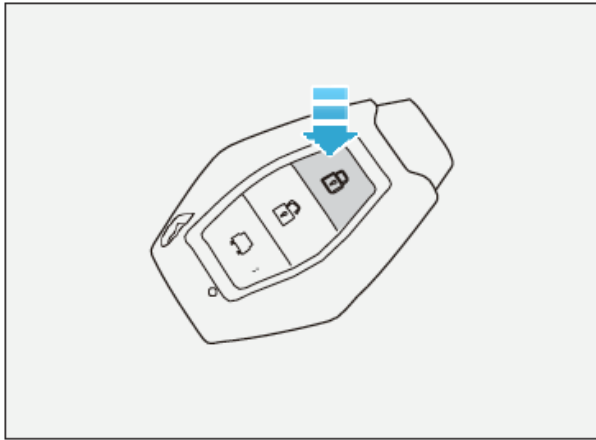

Within the operating distance of the remote key, shortly press the unlock key on the remote control key once to unlock all the doors, and the left and right turn signal flashes for 2 times to exit the fortified state.

When ACC is "ON", the remote control is invalid

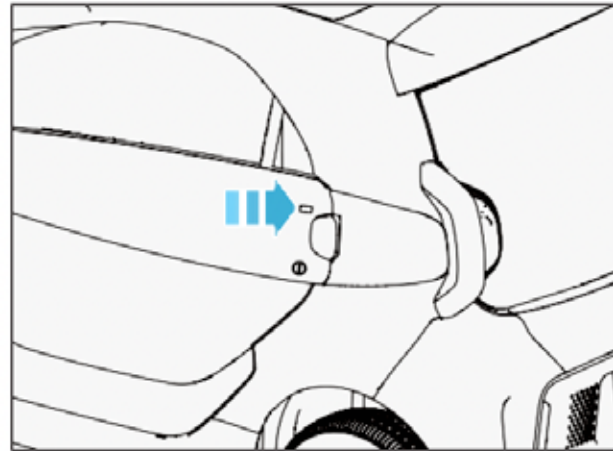

#### \* keyless entry control

When the start switch is in the "OFF" position and the door is locked, the user presses the micro switch on the handle of the door with the smart key within 1.5 meters from the door to unlock the two doors and the turn signal flashes once.

When the start switch is in the "OFF" position and the door is fully closed and unlocked, the user carries the smart key within 1.5 meters from the door and presses the micro switch on the door handle to close the door, and the turn signal flashes twice.

#### Remote learning function

Learning steps for the remote control: small light on - off - on - press the brake pedal twice, and the two keys learn successively. Press the unlock and lock buttons simultaneously while learning.

After learning successfully, the double flashing indicator on the central control screen flashes once. After learning successfully, press the brake pedal or turn off the small light to exit the learning mode

Front door

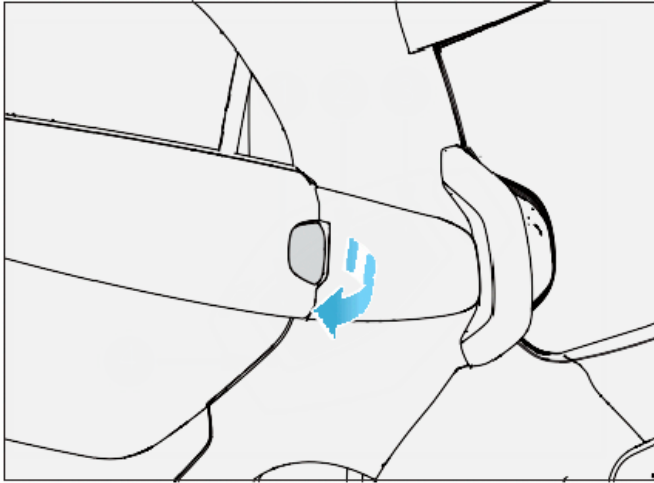

Open the front door

When the vehicle is unlocked, pull the front door switch outwards to open the front door.

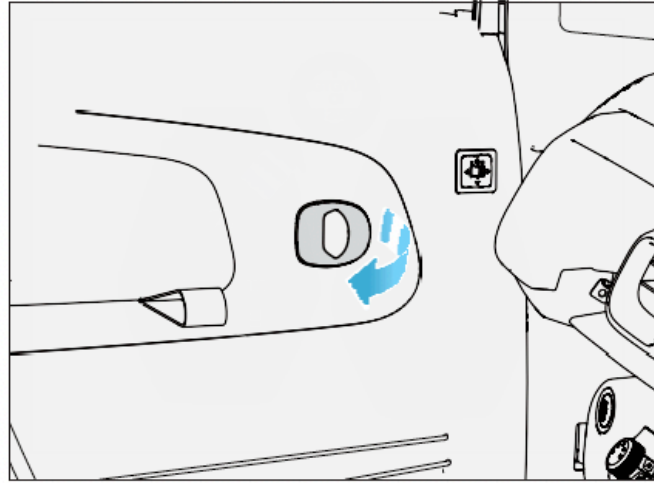

Inside unlocking door

When the person is in the car and the door is locked, pull up the inner handle of the door to unlock the door.

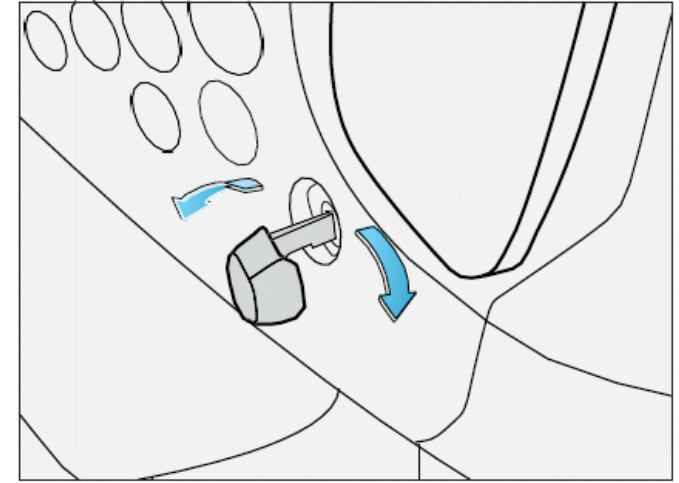

A mechanical key unlocks the door

With the key to open the left front door, the right door joint unlocked;

Lock the left front door with the key (switch off) and the right door with joint closure.

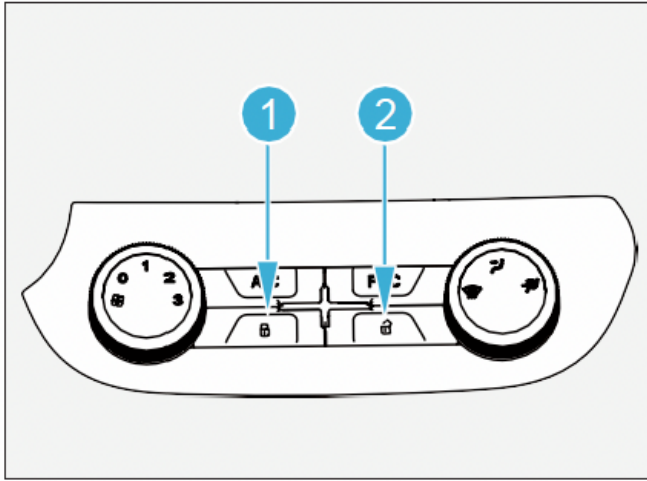

### Central control door lock switch

#### 1 lock key

Operation lock switch, switch on, double linkage lock.

#### 2 unlock key

Operate the lock unlocking switch, the switch is on, and the double door jointly unlocks.

#### ⚠ ATTENTION

- In order to protect the lock motor,
- do not lock and unlock continuously in a short time.

#### The door locks automatically

When the vehicle starts, all doors will automatically lock when the speed is greater than 15km/h.

#### Door automatically unlock

The vehicle stops after driving, the starting switch is in the state of "OFF", and all the doors will be unlocked automatically.

#### Crash unlock function (for vehicles with airbags)

When the car collides, the sensor collects the signal and sends it to BCM. When IGN is ON, BCM responds and unlocks the door. After a collision, the turn signal continues to flash until IGN/ACC-OFF.

#### ⚠ WARNING

- Do not leave children or disabled persons alone in the car.
- Once the lock button is pressed, the door is locked immediately. Children or persons with disabilities have difficulty getting out of the vehicle to protect themselves in an emergency. A locked car door in the event of an accident would make rescuing them more difficult.

## Anti-theft alarm function

### Fortified function

ACC is OFF, press the lock key of the remote control, the vehicle enters the state of fortifying, any door is opened abnormally, BCM enters the state of alarm, the left and right turn signal will blink for 30S, the horn will honk for 15 times continuously, the state of the inner door will not change for 30S, the alarm will be over; If you move the door switch again, BCM will alarm again.

### Alarm removed

Door trigger alarm lifting mode: press the lock button or car search button on the remote control to remove the alarm; Press the unlock button of the remote control to cancel the alarm and exit the fortified state. ACC trigger alarm lifting mode: ACC from ON to OFF mode, press the lock key or car search key of the remote control to remove the alarm; Press the unlock button of the remote control to cancel the alarm and exit the fortified state.

In the fortified state, remote unlock, if there is no car door or ACC/IGN power within 30 seconds, automatic lock, and return to the fortified state.

## Tailgate

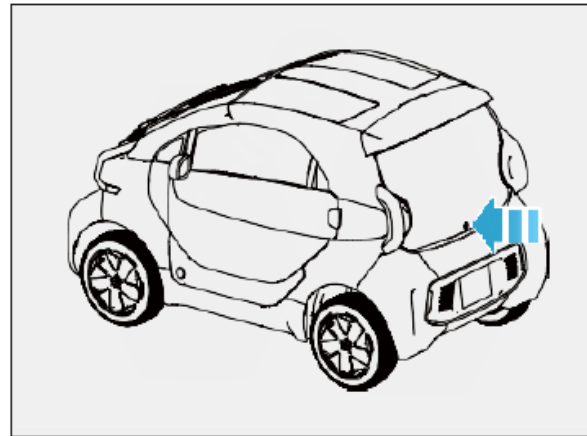

### Open the tailgate

When the vehicle is unlocked, press the tailgate trigger switch to open the tailgate

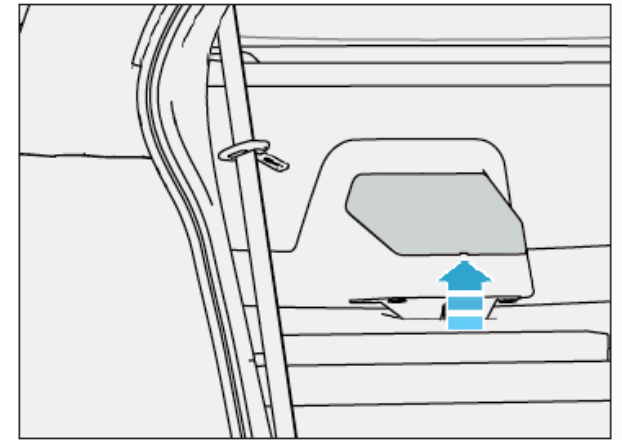

### Open the tailgate in an emergency

In case of an emergency, the emergency switch cover on the tailgate interior panel can be pry open from the car with a mechanical key



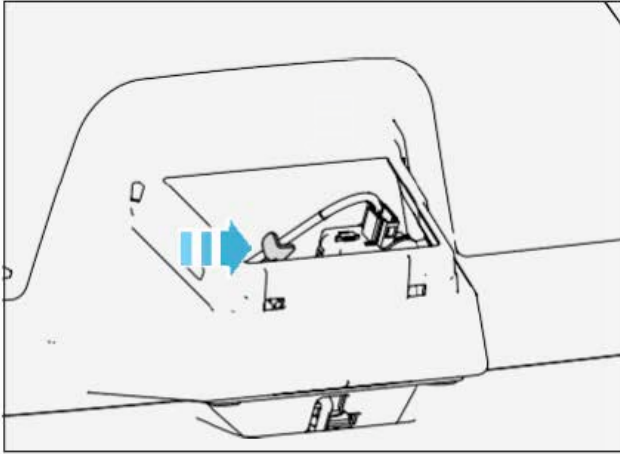

Unlock the tailgate by turning the emergency opening handle on the tailgate lock.

 **WARNING**

- When opening or closing the tailgate, check the safety of the surrounding area to ensure that no one is in the swing range of the tailgate.
- When closing the tailgate, take extra care to avoid pinching fingers and other parts.
- Do not carry passengers in the trunk, otherwise in the emergency brake or collision, it is easy to cause serious injury or even death.

## Power window

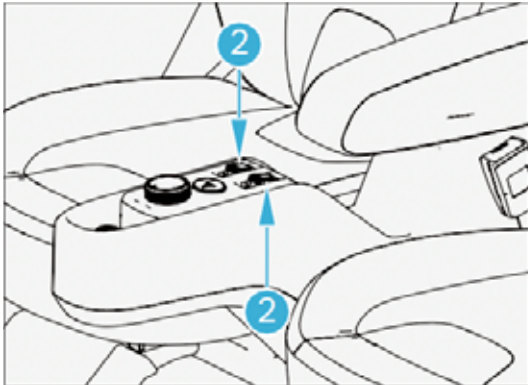

The power window can be operated when the starting switch is in the "ON" state.

### Operate the power window up

- 1 driver side power window button
- 2 passenger side power window button

Raise the window control button and hold there, the window up; Release button, the window can stop at any position.

During the window motor rising output, if the glass is blocked or in place, stop the output within 300ms.

If the window motor is idling (the feedback current has been the normal working current of the motor), the output will stop within 8s.

### Operate the power window down

Press the window control button and hold there, the window down; Release button, the window can stop at any position.

If the time is 500ms, release the button and the motor will stop output.  
If pressing time:  $150\text{ms} < T < 500\text{ms}$ , the window will automatically drop to the bottom.

If the press time is less than 150ms, only a little moving work is done; The window is abnormally stuck during the drop, or drop to the bottom, the output stops within 300ms.

### Open/close windows after remote control lock

Long press the "lock" button of the remote control, the window starts and closes the window in turn, and loosen the "lock" button to stop raising the window. Long press the "unlock" button of the remote control, the window will start down in turn, and release the "unlock" button to stop. In the process of automatic window closing or window opening, if the stop gear is stuck, the window will stop output within 300ms. If the motor is idling all the time during the output period, the output will be closed within 8s. Remote control automatic window closing or window opening start process: left front window start output first, 0.3s after the right front window start output.

### WARNING

- Before closing the power window, make sure that the head, hands or other body parts of the person near the power window and the occupant are inside the car. If the head, hands or other body parts get stuck in the closed window, serious injury or death can result.



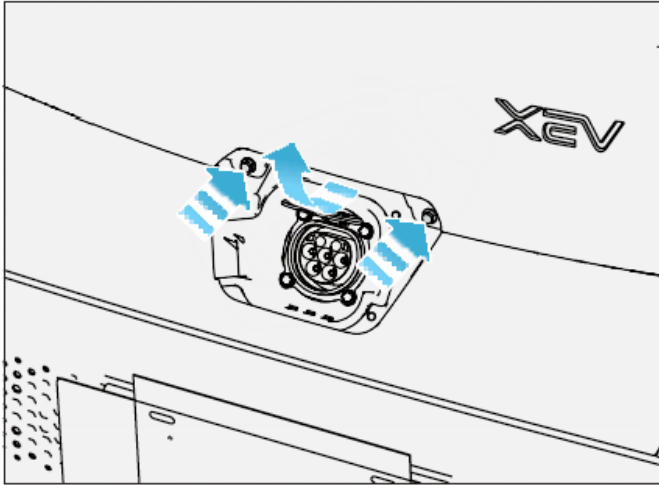

### Open/close the front cockpit cover

Open the front charging port cover plate, remove the two front cockpit cover plate retaining bolts using a sleeve, carefully pry open the front cockpit cover plate and remove. Close side opposite.

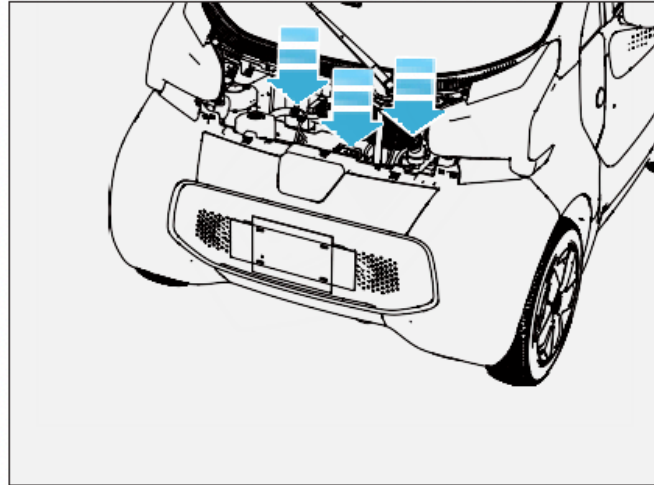

### Front cockpit cover

- front cabin warning safety tag.
- Do not put your hand on the rotating parts, the fan may work when the motor is running and when it is stopped.

#### WARNING

- For safety reasons, the front cockpit cover must be tightly closed at all times while driving.

## Front windshield wiper operation

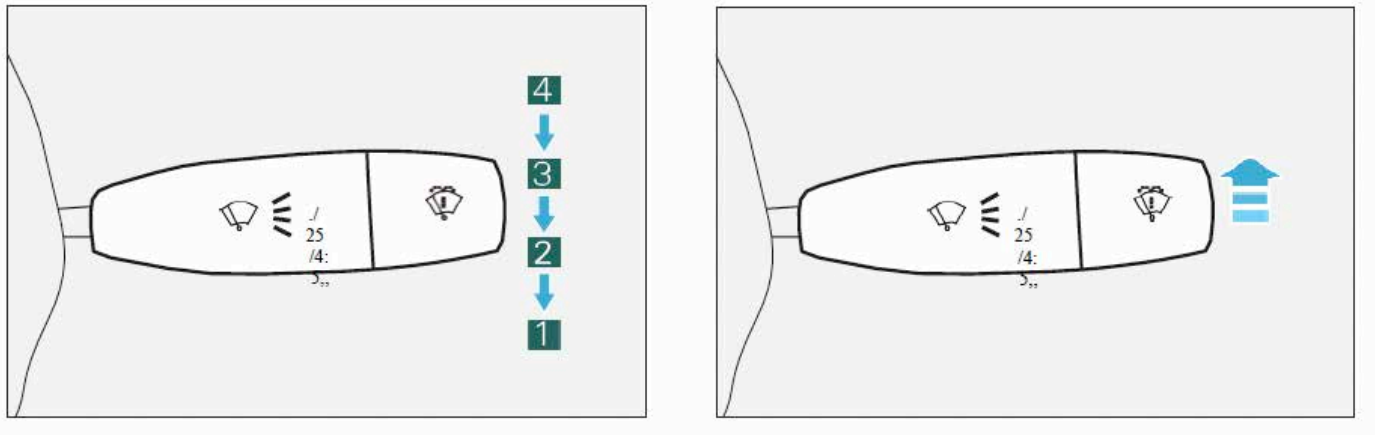

When the starting switch is in the " ON" state, the front windshield wiper and scrubber can be operated.

1 OFF: initial position

From the initial position OFF, pull the wiper switch upward, and they are as follows:

- 2 INT: Wiper intermittent gear
- 3 LO: wiper low gear
- 4 Hi: wiper high gear

The speed of the intermittent wiper can be adjusted by moving the wiper switch upwards from the initial position OFF to the position INT.

Pull the wiper switch upward from the initial position OFF to the position LO, and the wiper will operate at low speed.

From the initial position OFF, pull the wiper switch upward to the HI position and the wiper will run at high speed.

Put the front wiper gear switch in the OFF position, and the front wiper brush will automatically return to the position in the low speed wiper mode; Put the key in the ON state.

If the front wiper brush is not ON the return point, it will automatically return to the position with low speed wiper.

## Scrubber operation

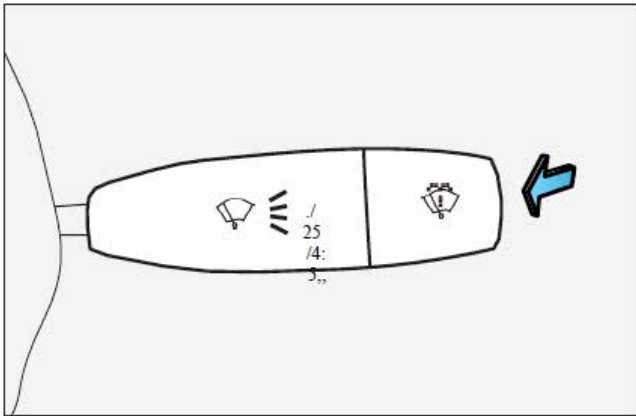

### ⚠ ATTENTION

- In winter, if the windshield glass is frozen or has snow, you should clear the ice and snow on the wiper arm and turn on the defrost device before using the wiper.
- Do not use wipers on dry windshield Windows.

## Wash/wiper

If the front wiper gear switch is in OFF or INT file, the front wiper will continue to work at a slow speed after 0.4s; If the front wiper gear switch is in LO or HI, the front wiper shall remain in the original working state.

The cleaning cycle can be adjusted according to the amount of water spraying: if the time of washing switch on is less than 300ms, the wiper will stop after one week; if the time of washing switch on is more than 800ms, the wiper will stop after two weeks; if the wiper switch is on all the time, the wiper will keep on the brush.

Until the wash switch is disconnected.

## Lighting device

<b>Light distribution view</b> .....	43
Light distribution view .....	43
<b>Lights</b> .....	45
Lamplet .....	45
Passing beam light .....	45
Driving beam light .....	45
Overtaking signal .....	46
Hazards warning light .....	46
Turning light .....	47
Brake light .....	47
Reversing light .....	47
Front top light .....	48
Luci diurne .....	49
Remote control lights off function .....	49

Viewport of the lights distribution

Capitolo 3

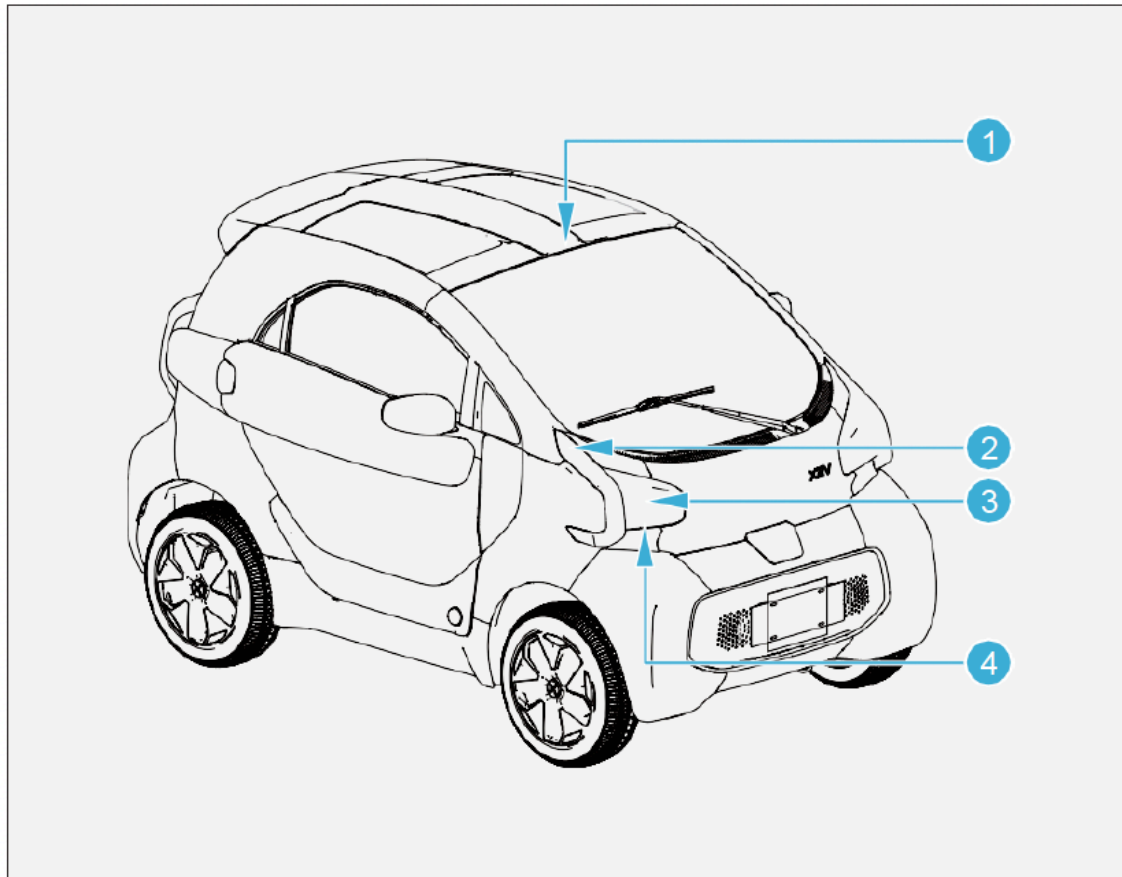

1. front top light
2. DRL light
3. driving beam light
4. passing beam light

Light distribution view

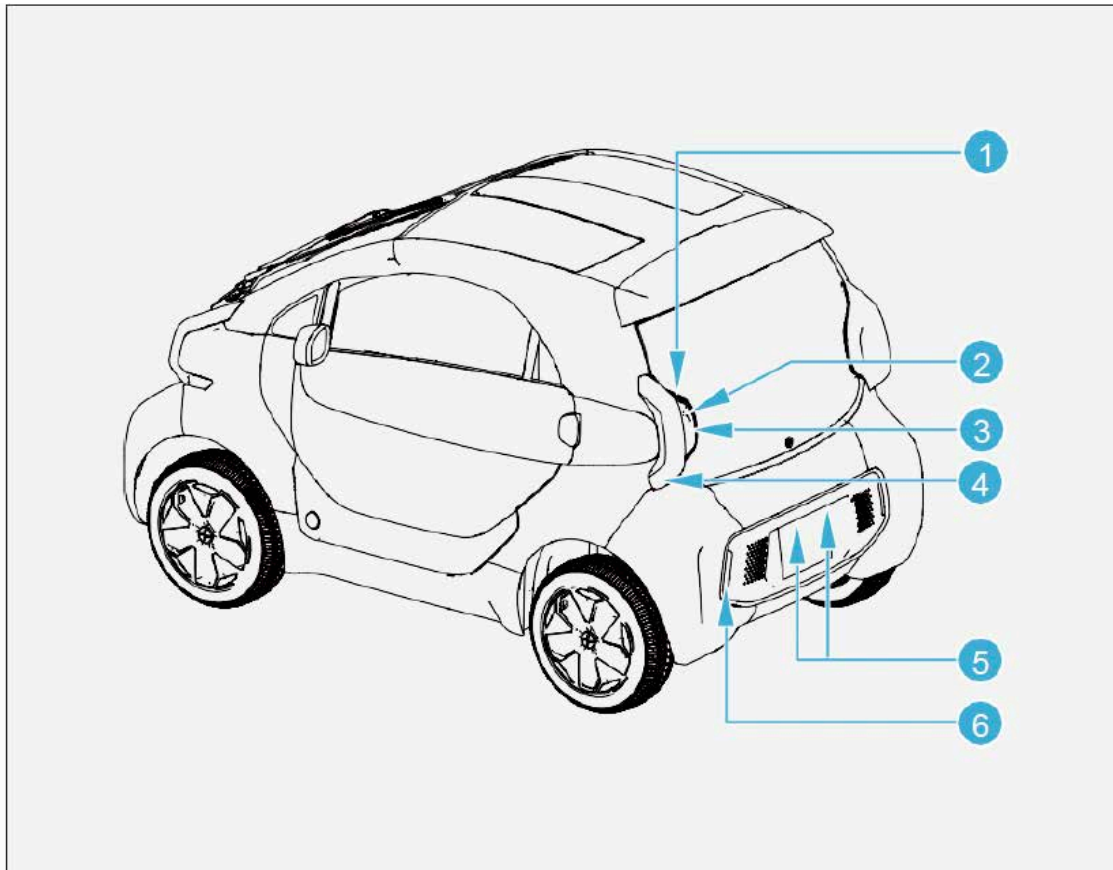

1. position light
2. reversing light
3. brake light
4. rear turn signal light
5. registration plate lamp
6. rear reflector





### Lamplet

### Passing beam light

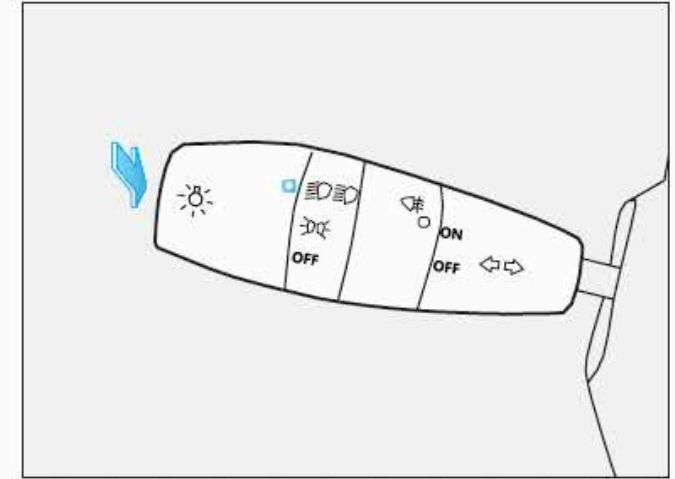
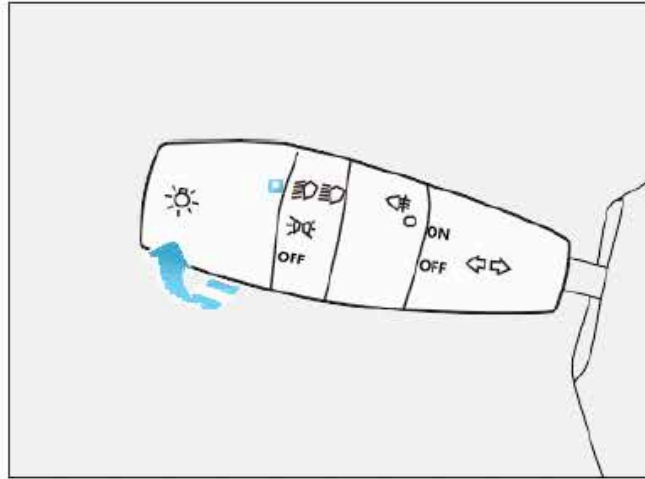
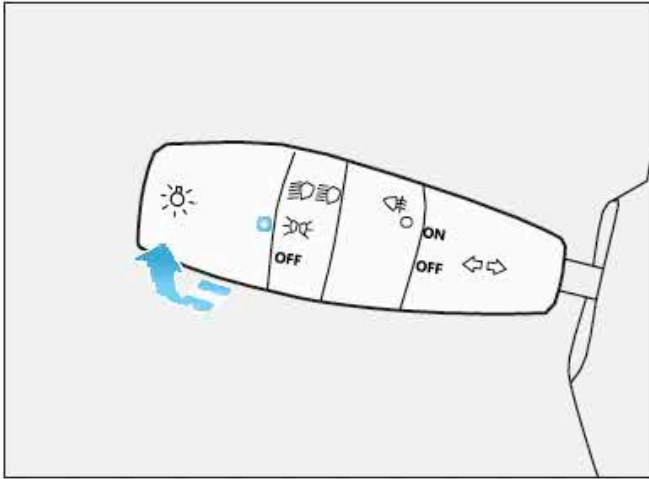
### Driving beam light



Turn the light switch end knob OFF  to position lamplet (including background light and license plate light) on. At the same time, the indicator light  of the lamplet in the combined instrument is lit.

The starting switch is in the state of "OFF". When the lamplet is turned on and the left front door is opened, the alarm prompt function is activated if the lamplet is not turned OFF. At this point, BCM will drive the built-in buzzer to sound alarm in 1Hz cycle until the left front door is closed or the small

When the lamplet is turned on and the left front door is opened, the alarm prompt function is activated if the lamplet is not turned OFF.

At this point, BCM will drive the built-in buzzer to sound alarm in 1Hz cycle until the left front door is closed or the small light is off or ACC and IGN are turned on. When the starting switch is in the "ON" state, turn the light switch end knob OFF to position 

The starting switch is in the state of "ON", turn ON the passing beam light and push the light switch downward, and the driving beam is ON 

At the same time, the passing beam light and lamplet are lit. The driving beam indicator in the combined instrument lights up. When the driving beam is on, the passing beam will be off. Switch to the passing beam light when you pull the light switch up to the initial position.

### Overtaking signal

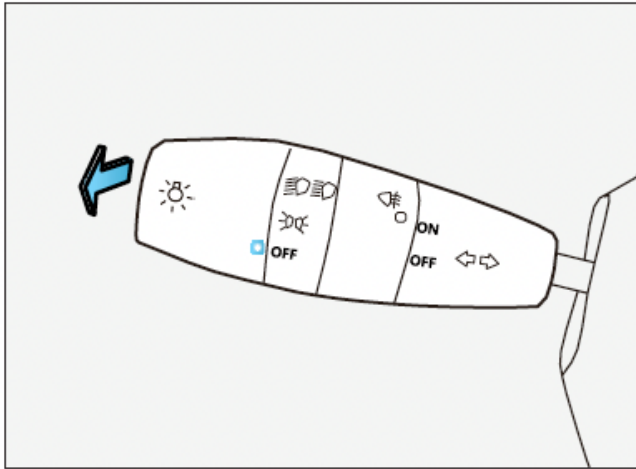

When overtaking, turn on the left turn signal in advance, pull up the light switch, the driving beam is on, let go after the switch back to the initial position, the driving beam is off.

When overtaking, continuously pull the light switch upward to send out the overtaking signal.

### ⚠ WARNING

- When driving at night on roads without central isolation facilities or without central lines, do not use driving beams within 150 m of approaching vehicles from the opposite direction.
- Do not use driving beams on narrow bridges or narrow roads without central isolation facilities or centerlines to meet non-motor vehicles.
- Do not use driving beams when turning through an intersection controlled by traffic lights.
- In the case of no street lamps, poor lighting or low visibility in the case of fog, rain, snow or dust, the following vehicle driving in the same direction shall be in close proximity to the leading vehicle driving in the same direction.
- Through the sharp bend, slope, arch bridge, crosswalk or no traffic signal control intersection, should alternate the use of driving beams, passing light signal.

### Warning lights

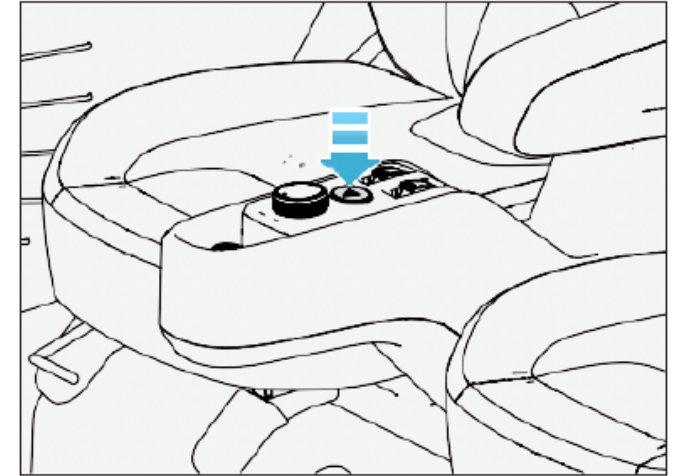

The hazard warning light switch is located in the console. When the hazard warning light is turned on, the turn signal flashes, and the combination instrument flashes. The turn signal switch does not work when the hazard warning light is on. Hazard warning lights should be used to draw the attention of other vehicle drivers when:

1. Unable to continue driving because the vehicle had broken down.
2. In a traffic jam, the cars are at the end of the stream.
3. Emergency traction of other vehicles or when being towed.

### Turning lights

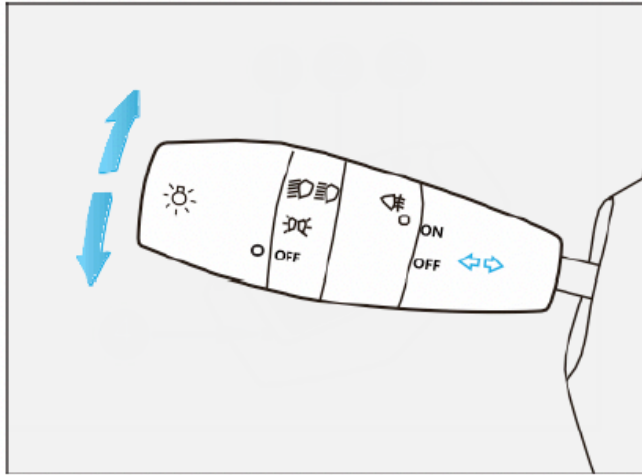

1. The starting switch is in the state of "ON", pull the light switch handle forward, and the turn signal ON the right side of the car flashes.
2. Light switch handle automatically return to position, turning signal off; You can also manually reset the light switch.
3. Move the light switch handle forward or backward, and the turn signal will light up. When the steering wheel returns to the straight driving position, the light switch handle will automatically return to the position and the turn signal will go out; the light switch can also be reset manually.

### Brake lights

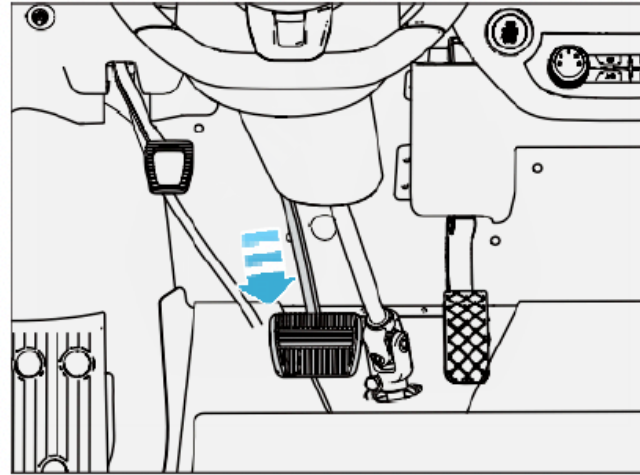

The starting switch is in the state of "ON", press down the brake pedal, and the brake lamp is ON.

### Reversing light

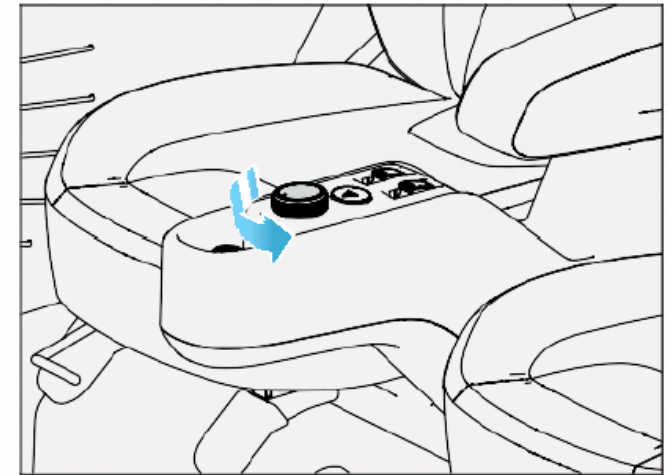

## Top light

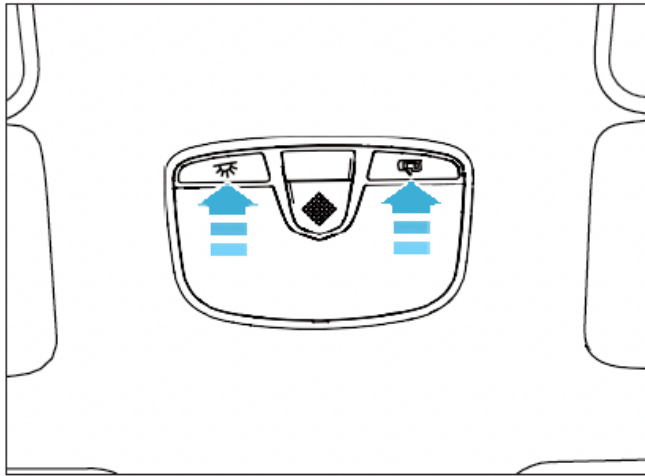

### ⚠ ATTENTION

- When the starting switch is in the "OFF" state, it is in the all three cases, the front top light will be linearly extinguished within 0.7s: Close all doors, after 10S delay, front top light goes out.
- Close all the doors, press the remote lock button, central control complete the lock, and the top light is off.
- Close all doors, turn the starting switch to "ON", and the top light goes off.

### ⚠ ATTENTION

- Start switch is in OFF mode, press the remote control "unlock" key, implementation of the unlock, and the top light within 0.7s is lit linearly, and the top light is lit and then extinguished That program is executed according to fade out function.
- Starting switch is in OFF mode, all doors are closed well, press the "lock" button on the remote control and execute lock function, and the top light is linearly extinguished within 0.7s.

### Front top light

Press the left front top light switch on the front side, the front top light is lit.  
Press the front top light switch again, the front top light is off.

### Door controlled switch

When you open any door, the front top light is linearly lit within 0.7s. After all the doors turning off 0.7s, front top light goes out linearly. Press again the door controlled switch to turn off this function.

## DRL function

When driving in the daytime, the starting switch is in the state of "ON". If the lamplet is not turned ON, the day running light will be ON in the daytime. The lamplet is turned on or the starting switch is in the state of "OFF", and the day running light is turned OFF during the day.

## Remote control lights off function

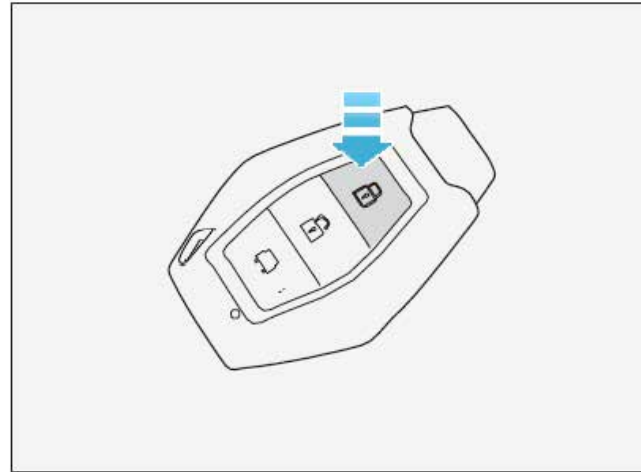

## Safety device

Seat belt _____	51
Use seat belt _____	52
Seat belt pretensioner _____	54

### Seat belt

Properly wearing a seat belt can effectively reduce the possibility of injuring the driver and passenger in an accident.

**▲ DANGER**

- Drivers and occupants should use seat belts properly at all times. Failure to do so will increase the likelihood or severity of injury in an accident.
- When a vehicle is in motion, wearing a seat belt properly will ensure an emergency brake or reduce the risk of injury to the driver and passenger in the event of an accident.
- Pregnant women and people with disabilities should also use seat belts correctly.
- Seatbelts should not be shared, even among children.
- Avoid overreclining the seat back. When a vehicle is involved in a frontal collision, the more reclined the seat, the greater the chance of serious injury or death.

**▲ DANGER**

- Check the seat belt system regularly. If the safety belt system is found to be nicked, worn or loose, the safety belt assembly or assembly must be replaced. Do not disassemble or modify the safety belt system.
- Keep seat belts clean and dry. If you need to clean the belt, use a neutral soap solution or warm water. Do not use bleach, dye or detergent to clean the seat belt.
- Seat belts (including bolts) used in a serious crash must be replaced. The entire assembly should be replaced even for minor damage.

#### Why is it necessary to wear seat belts?

Seat belts can slow down the driver's inertia and reduce the impact injury to the driver as much as possible in the event of a frontal collision.

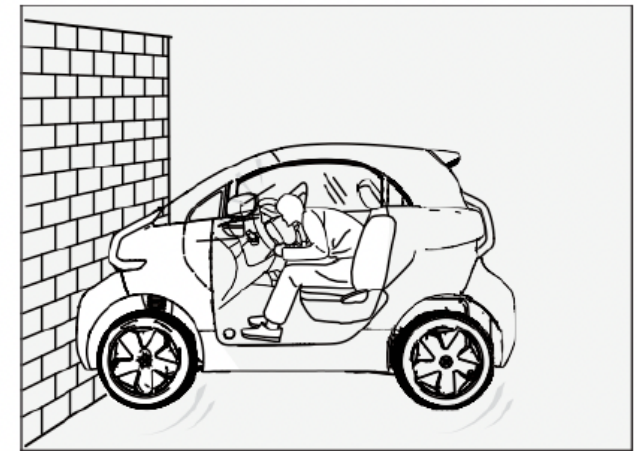

#### The physical principle of the frontal collision

The vehicle and occupant in the process of running have energy (kinetic energy), its strength depends on the speed of the vehicle and the mass of occupant, the greater the speed and mass, the stronger the energy released in the collision. The speed plays a decisive role. If the speed is increased from 25 km/h to 50 km/h, the release of kinetic energy will increase fourfold. After the vehicle collision, the occupant without the seat belt will still move forward at the speed before the collision due to inertia, but the vehicle is not moving with the occupant at this time. The crew could be seriously injured.



### Consequences of not wearing a seat belt

Even at a low speed, the force on the human body in a collision is so great that the occupant has no control over his or her body. An occupant who is not wearing a seat belt will be thrown forward, potentially causing serious injury to any object in the vehicle.

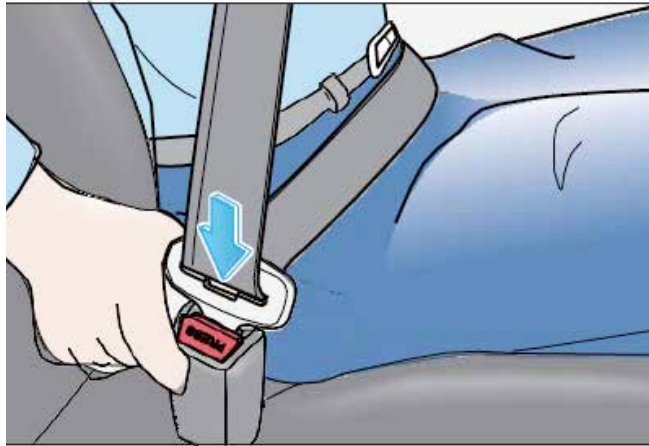

**! ATTENTION**

- Wear your seat belt properly before driving to reduce the risk of an accident.
- Ensure that the seat belt is properly worn in accordance with the relevant instructions in this manual.

Wear a three-point seat belt

- Adjust the seat properly: page 56
- Slowly pull the safety belt out of the retractor, around the chest and crotch, insert the safety belt lock into the latch, hear "click" sound, indicating that the lock and latch are locked.
- Pull the seat belt to make sure it is locked.

**! WARNING**

- After inserting the latch, make sure that the lock and latch of the safety belt are locked and the safety belt is not twisted.
- Coins, paper clips and other objects are forbidden to be inserted into the latch, so as not to affect the correct matching of the lock and the latch.
- If the safety belt does not work properly, please contact the XEV new energy vehicle authorized service station for maintenance immediately.





### Adjust the position of the three-point safety belt

The abdominal seatbelt should be placed as low as the hips, then pull the shoulder seatbelt up through the latch to adjust the seatbelt into position. Do not allow shoulder seatbelts to touch the neck or slip off the shoulder.



### Unfasten the seat belt

- Press the red button beside the lock with your finger, and the lock will pop out automatically.
- Hold the lock, rewind the seat belt and return the seat belt to the retractor.

**⚠ WARNING**

- Do not unfasten the seat belt while the vehicle is moving or before it comes to a complete stop to avoid serious injury in the event of an accident.
- When unwinding the seat belt, hold the upper end of the safety belt latch tongue with one hand and press the red button beside the lock buckle with the other hand to return the safety belt to the retractor to avoid personal injury caused by the safety belt winding too fast.



**⚠ WARNING**

- An abdominal seat belt that is too high or too loose can cause serious injury or death to the occupant due to body sliding in a collision or other accident.



**⚠ WARNING**

- Pregnant women are more special than the general people, they should pay more attention to their own safety and the safety of the unborn fetus, and must wear seat belts correctly when driving or traveling by car.

**Seat belt pretensioner**

When the seat belt pretensioner is working, the seat belt pretensioner will automatically tighten the seat belt when the vehicle has a moderate to severe frontal impact, reducing the forward movement of the driver and the occupants. The seat belt pretensioner is located in the seat belt retractor.

**Pregnant women must wear seat belts correctly**

- Adjust the seat to the right position.
- Hold the lock and slowly pull the belt over your chest, and make sure the belt is as low as possible, and do not press on your abdomen.
- Insert the lock into the corresponding latch until a "click" sound is heard, indicating that the lock and latch are locked.
- Pull shoulder seatbelts up parallel to the upper body, tighten hip seatbelts, and make sure the lock is properly engaged

Charging device	Instrument & control devices	Lighting device	Safety device	Vehicle device	Starting & driving	Emergency treatment	Repair & maintenance	Technical information
-----------------	------------------------------	-----------------	---------------	----------------	--------------------	---------------------	----------------------	-----------------------

## Vehicle device

<b>Seats</b> _____	56	<b>Air conditioner</b> _____	62
<b>Rearview mirrors</b> _____	57	Introduction to Air Conditioning Panel _____	62
Exterior rearview mirror _____	57	Functional operation _____	63
Interior rearview mirror _____	58	<b>Multimedia display screen</b> _____	65
<b>Internal equipment</b> _____	59	Multimedia main interface introduction _____	65
Door storage bag _____	59	Boot screen _____	66
Dashboard storage bag _____	59	Radio _____	66
Console storage box _____	59	Setting interface _____	66
Cupholder _____	60	Third-party application interface _____	68
Dashboard storage compartment _____	60	Bluetooth _____	69
Sunvisor _____	60	Phone call _____	69
Console USB _____	61		
Dashboard USB _____	61		
Phone holder _____	61		

### The importance of properly adjusting the seat

Proper seat adjustment ensures that the seat belt provides full protection.

**⚠ WARNING**

- When adjusting the seat, avoid collision between the seat and the passenger and luggage.
- Do not overrecline the seat.
- Do not adjust the seat during driving, so as not to lose control of the vehicle due to seat movement.
- Please do not place anything under your seat.
- After adjusting the seat, push the seat and seat back forward and backward to make sure the seat and seat back are securely locked.
- Check and make sure the seat belt is not twisted or clamped on the seat.



#### Seat position adjustment

Hold the middle of the lever and pull up. Slide the seat forward or backward to the desired position and release the adjusting lever.



#### Seat backrest Angle adjusting lever

Lean forward and pull the seatback Angle adjuster up. Then lean back to set the backrest at the desired Angle and release the lever.

**⚠ ATTENTION**

- The ideal seat position should ensure that your driving posture is comfortable, with your arms slightly bent to hold the steering wheel and your legs slightly bent to be able to control all devices.

Exterior rearview mirror

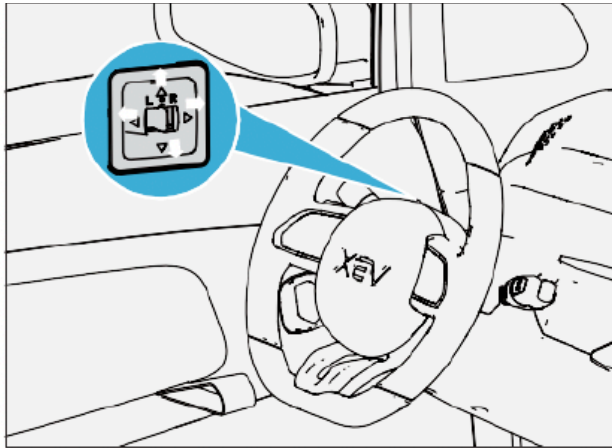

Start switch in "ACC" or "ON" state, dial the vehicle exterior rearview mirror adjustment switch knob to "L" or "R" position.

"L": left side.  
"R": right side.

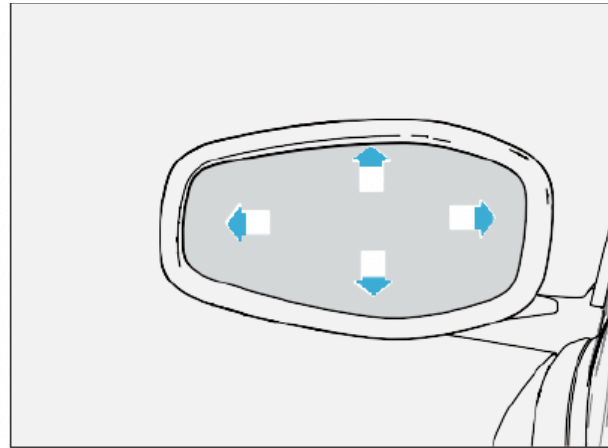

Turn the switch knob of the exterior rearview mirror in four directions to adjust the mirror lens to the best rearview position. After the adjustment is completed, the exterior rearview mirror adjustment switch knob should be moved to the middle position.

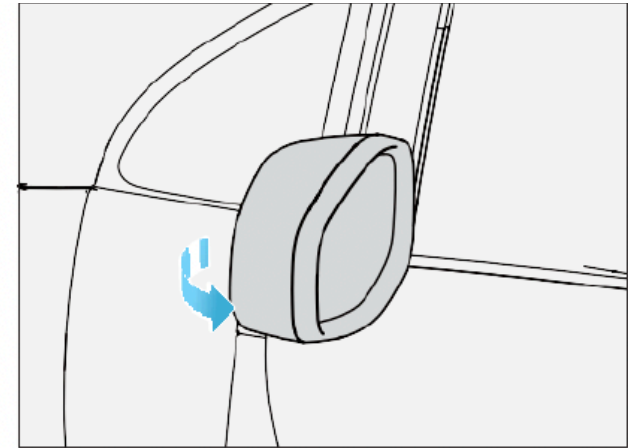

**Fold the exterior rearview mirror**

Push the exterior rearview mirror toward the rear of the vehicle, and you can fold the exterior rearview mirror.

**! ATTENTION**

- If the electric adjustment function of the exterior rearview mirror fails, you can gently push the outer edge of the mirror to adjust, and contact the XEV new energy vehicle authorized service station for maintenance as soon as possible.

## Interior rearview mirror

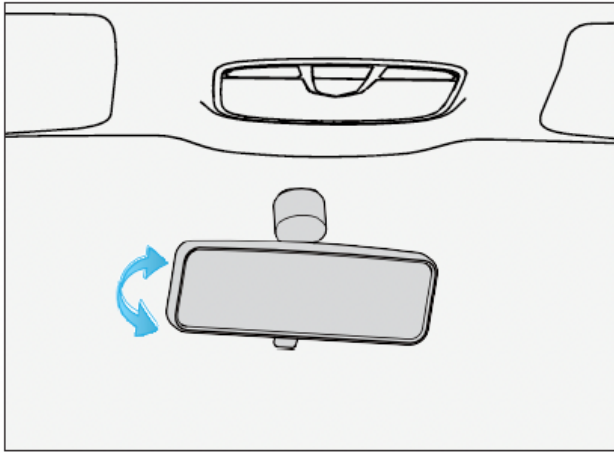

## Adjust the direction of the interior rearview mirror

Hold the interior rearview mirror, adjust it up and down, left and right direction, and adjust it to the best rearview position.

 **WARNING**

- Try to avoid adjusting the position of the rearview mirror when the vehicle is moving, so as not to cause the vehicle to lose control and cause injuries or even death.

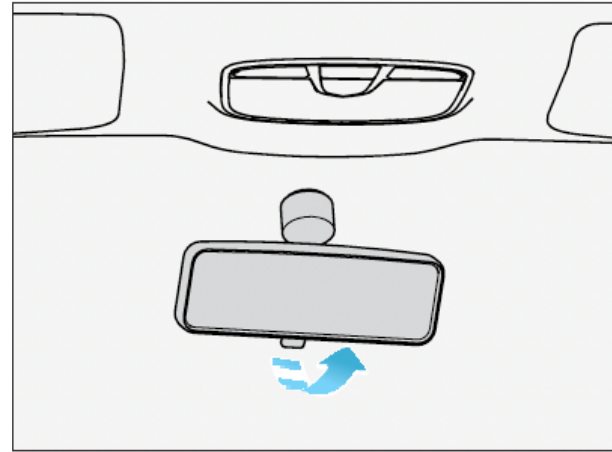

## Anti-glare switching operation

Turn the anti-glare dial at the bottom of the interior rearview mirror to change the angle of view of the interior rearview mirror to achieve "anti-glare". Pull back the anti-glare dial to return the interior rearview mirror to its normal position.

Door storage bag

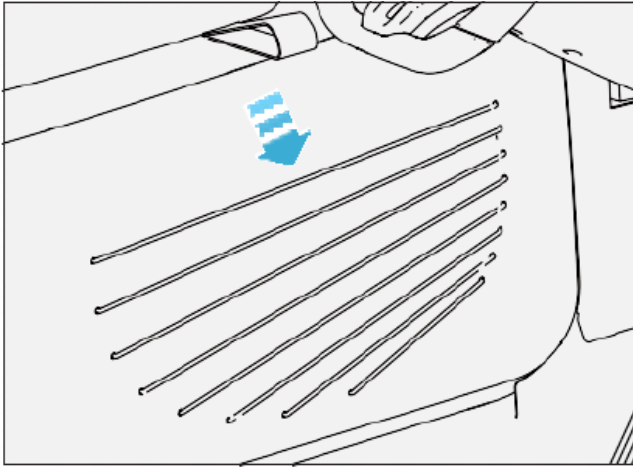

The door storage bag is located under the door interior trim panel, which can be used for storing small items such as maps and manuals.

Dashboard storage bag

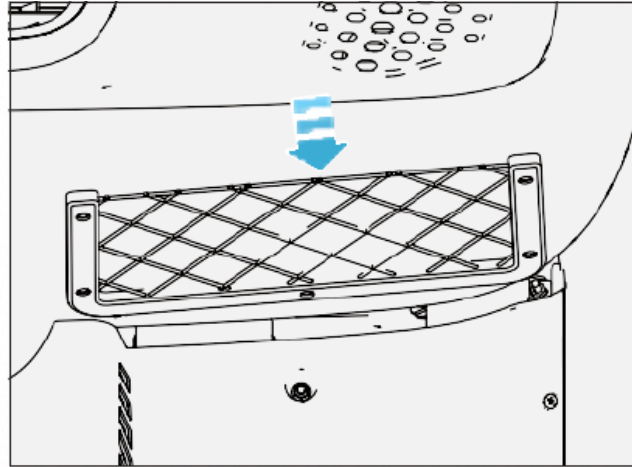

The dashboard storage bag is located at the lower right side of the instrument desk. It can be used for storing small items such as maps and manuals.

Console storage box

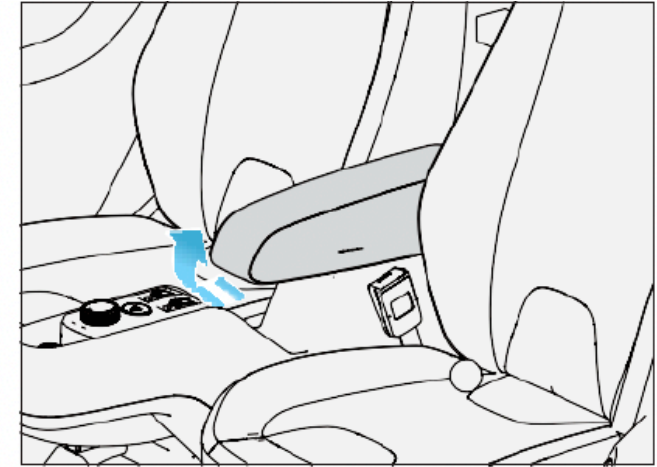

Console storage box can be used to place keys, cards and other small items.



### Cupholder

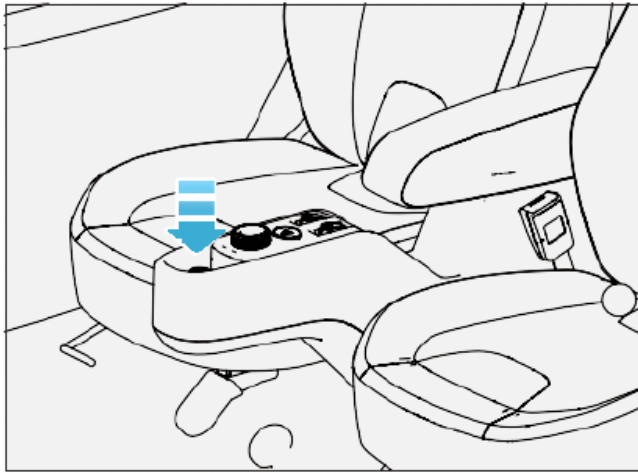

The console cup holder can be used to store drinking bottles or cups.

### Dashboard storage compartment

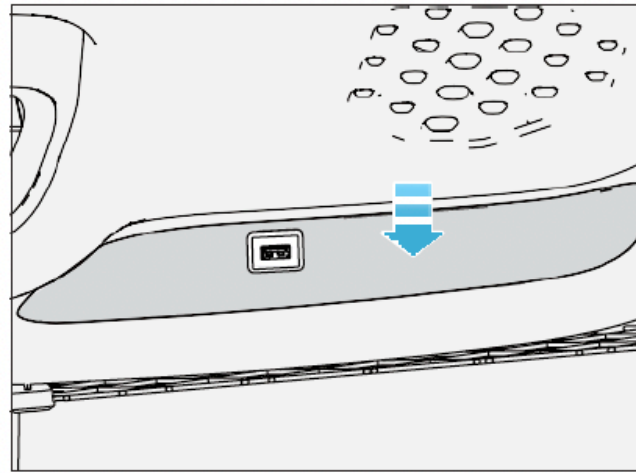

Dashboard storage compartment can be used to store some small items.

### Sunvisor

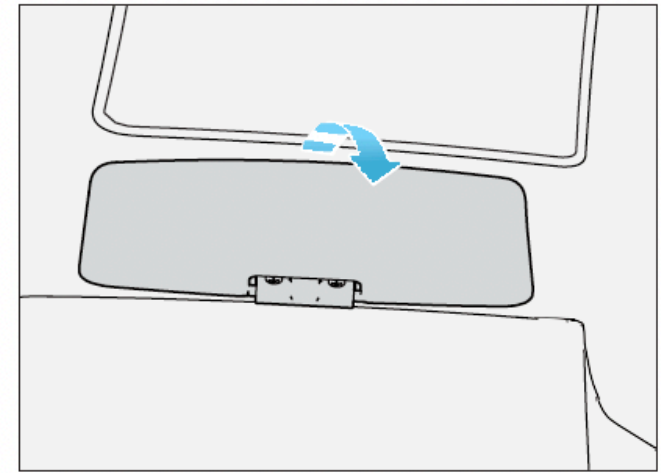

Turn the visor down to block the glare from the top of the front windshield, or up to the roof when not in use.



Console USB

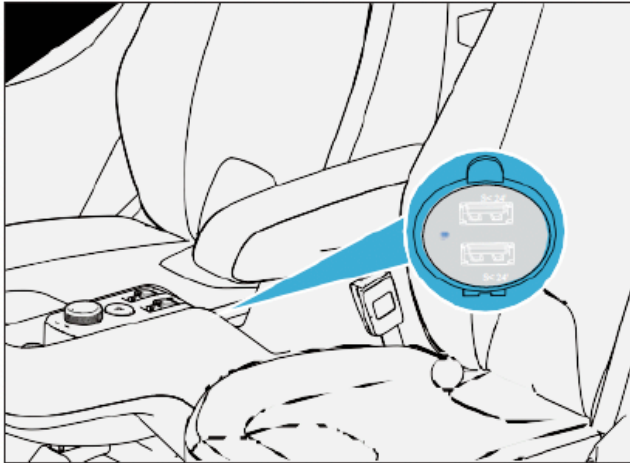

The console 5V power supply can be used to charge the mobile phone.

Dashboard USB

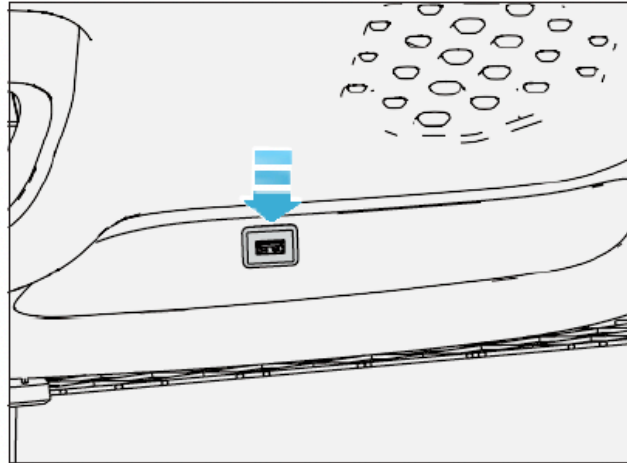

The console 5V power supply can be used to charge the mobile phone.

Phone holder

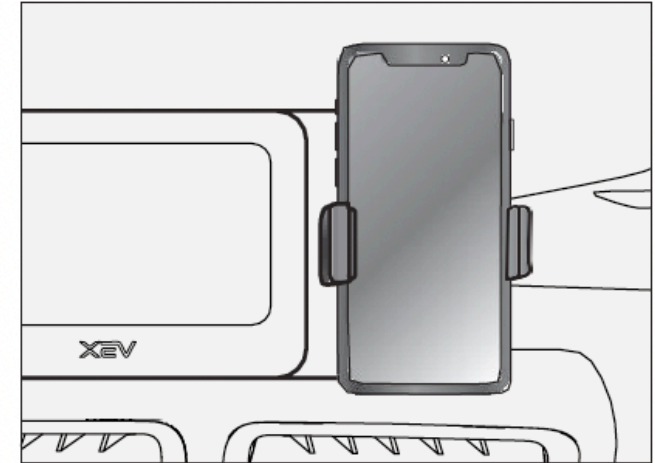

The phone holder on the right side of the center screen (low version) can be used for clamping and fixing the phone.

**!** ATTENTION

- The 12V power supply of the vehicle is not recommended to connect high-power electrical equipment.

## Introduzione al pannello del climatizzatore

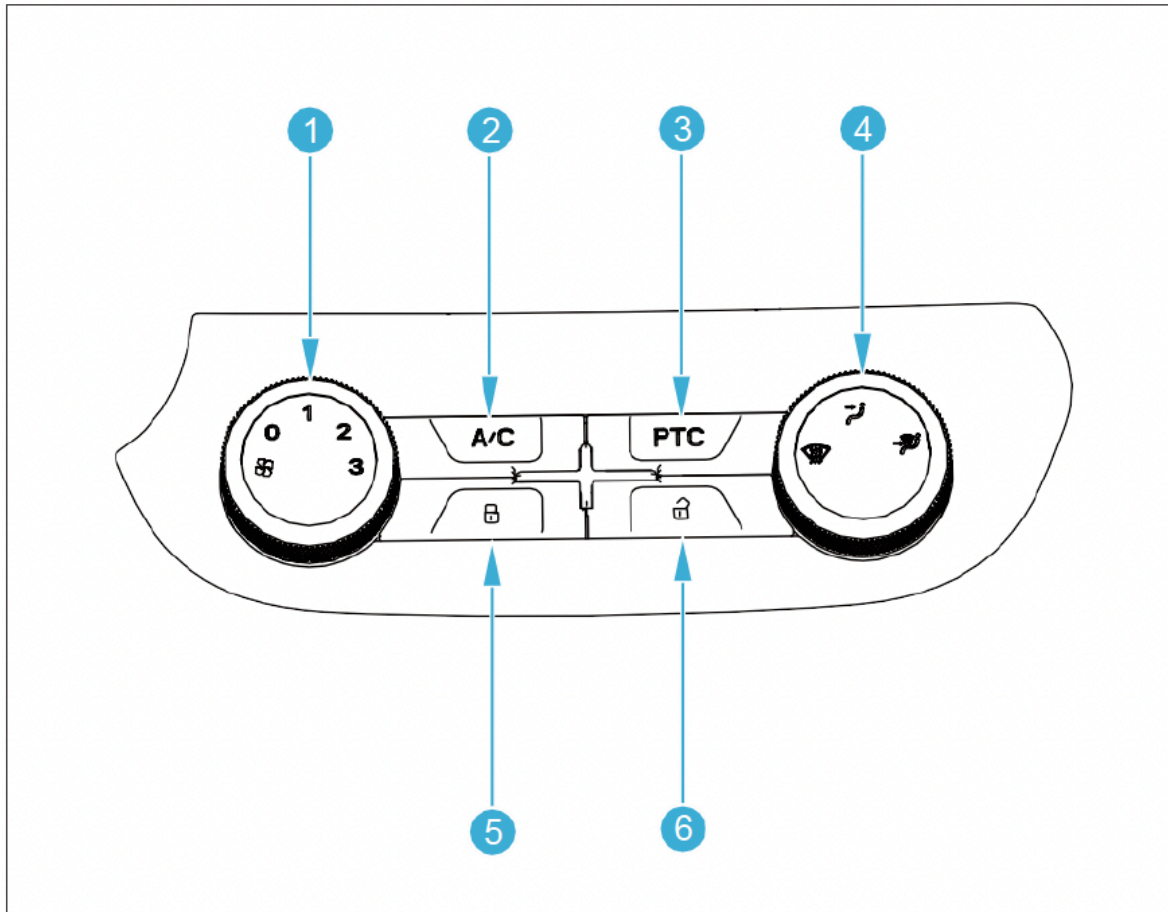

1. Air volume control switch knob
-----------------------------------

2. Compressor control button
------------------------------

3. Heating mode button
------------------------

4. Blow mode adjusting switch knob
------------------------------------

5. Central control lock
-------------------------

6. The central lock unlocked
------------------------------

Function operations

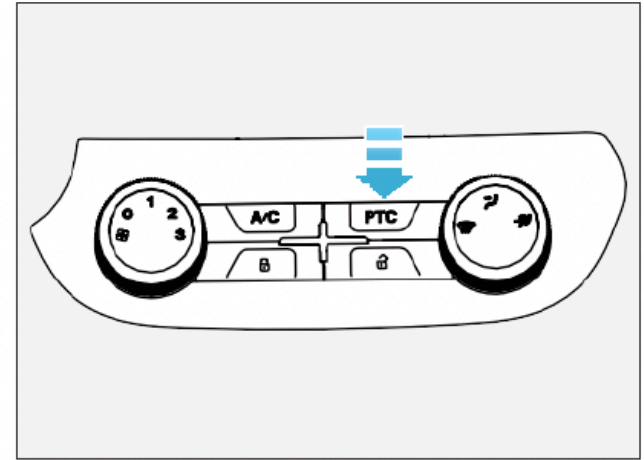
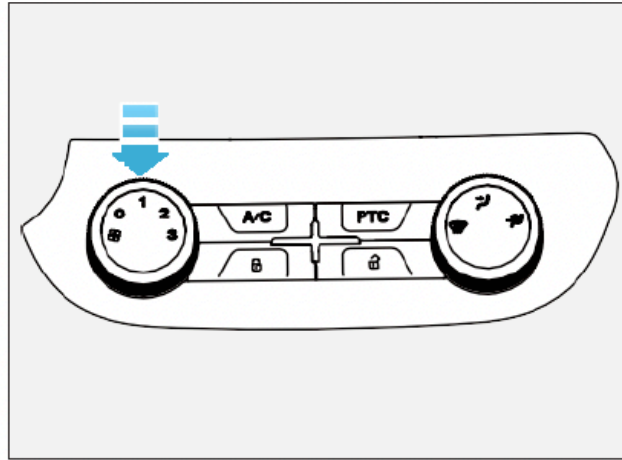
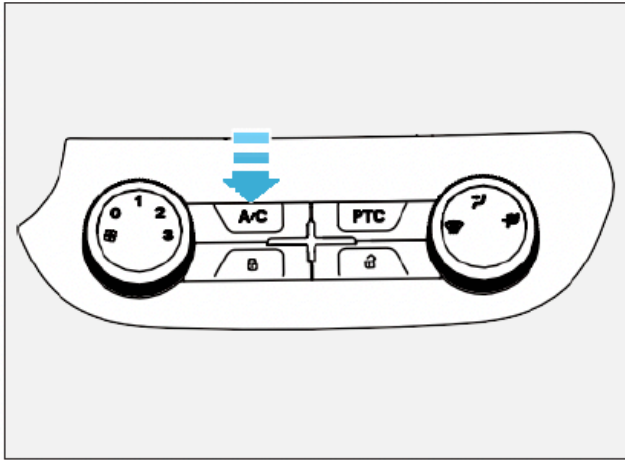

**Turn on the air conditioner**

The ignition switch is in the "ON" position, turn ON the blower, click the A/C icon, the air conditioning indicator light ON the central control screen will light up, and the air conditioning system will start working.

**Turn off the air conditioner**

Click the A/C icon again to turn off the air conditioner.

**The air flow**

Adjust the switch knob icon clockwise The air volume is switched between "01 gear 2 gear 3 gear".

**Turn on the air conditioning PTC heating**

Click the PTC icon, the air conditioner starts heating, click the PTC icon again, the air conditioner stops heating.

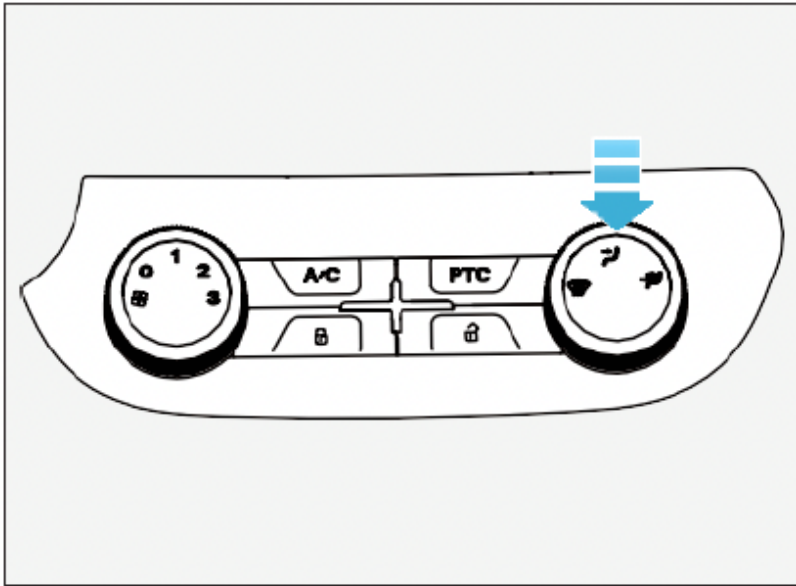

### Switch Ventilation Mode

Adjust the switch knob clockwise, and the ventilation mode switches between "front defrosting face blowing face blowing/front defrosting".

### Front defrosting mode

The air is blown out through the front windshield defrost outlet.

### Face blowing mode

Face blowing/front defrosting mode. The air is blown out through the outlet of the instrument panel.

### Face blowing/front defrosting mode

The air flow is divided into two parts and blown out through the instrument panel air outlet and the front windshield defrosting air outlet.

### ⚠ ATTENTION

- When your vehicle is in the heat of midsummer and the Windows are closed, the interior temperature will be very high. Before driving, it is recommended that you first open all the doors and Windows, turn on the air conditioning, and adjust the air volume to the maximum, so that the temperature in the car will drop rapidly.
- When the vehicle is not started, do not open the blower for a long time to avoid the depletion of battery power.
- When the refrigerant used in this car is R134A, and the refrigerating oil model is POE68 special oil. The use of incorrect refrigerant and refrigerant lubricating oil will damage the air-conditioning refrigeration system.
- When the refrigerant used in this car is R134A, and the refrigerating oil model is POE68 special oil. The use of incorrect refrigerant and refrigerant lubricating oil will damage the air-conditioning refrigeration system. Do not mix two refrigerants.

Multimedia main interface introduction

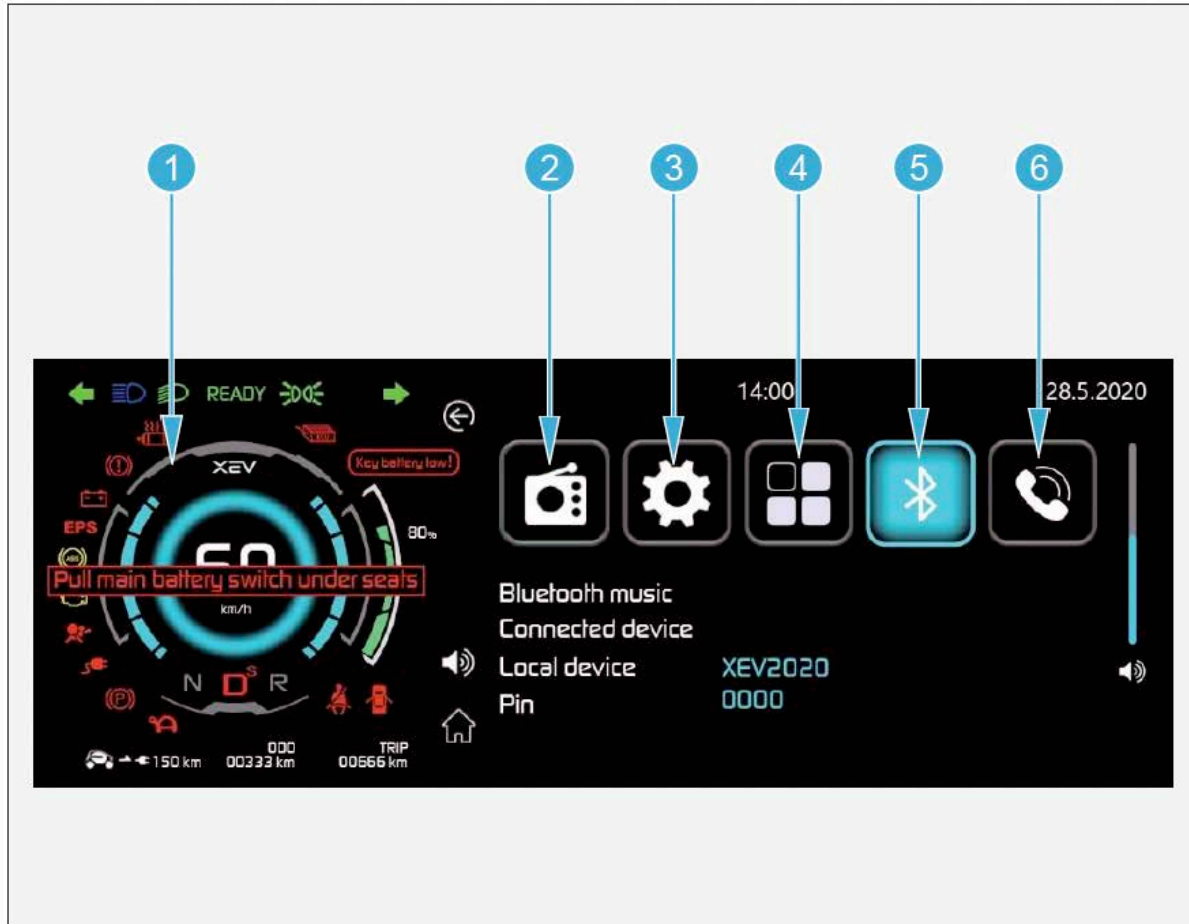

1. Instrument display interface
2. Radio interface
3. Setting interface
4. Third party APP interface
5. Bluetooth
6. Phone call

Boot screen



Boot screen: boot animation, voice welcome message "welcome to XEV"

Radio



Click on " ". The radio starts, FM after FM, click to save, at most could save five channels, . Click Digital Play to save the channel.

Setting interface



Click to enter into setting interface.

Multimedia button introduction

Click the button at the bottom of the screen " ", both could enter the main interface. Click the lower right corner , you can go back to the previous level. Volume adjustment, finger touch up and down.

Charging device	Instrument & control devices	Lighting device	Safety device	Vehicle device	Starting & driving	Emergency treatment	Repair & maintenance	Technical information
-----------------	------------------------------	-----------------	---------------	----------------	--------------------	---------------------	----------------------	-----------------------



The language selection page shows that the current support includes Chinese, English and Italian.



Vehicle information display page, including vehicle failure, vehicle prompt, battery and charging information.



Time and date Setting page.

Charging device	Instrument & control devices	Lighting device	Safety device	Vehicle device	Starting & driving	Emergency treatment	Repair & maintenance	Technical information
-----------------	------------------------------	-----------------	---------------	----------------	--------------------	---------------------	----------------------	-----------------------

The third party APP interface



User Guide display page, and the QR code is displayed on the right side.



Click the third party APP will be displayed, click app, could enter app page, the interface shows as above.

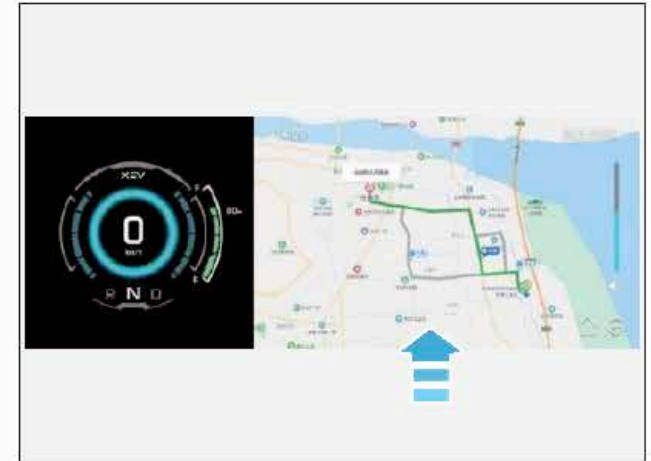

Click the map to display the half-screen map interface.



Bluetooth

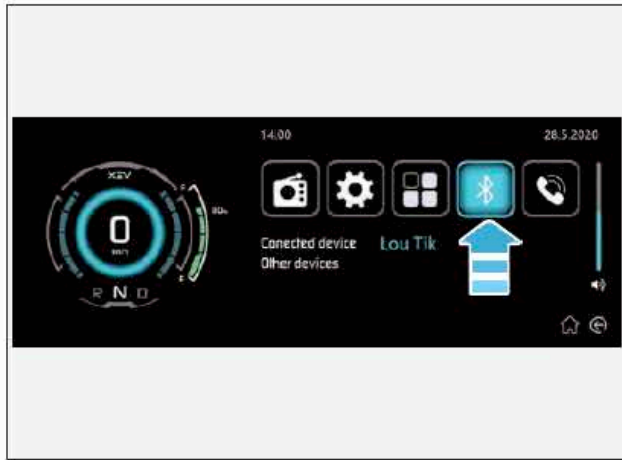

Phone call

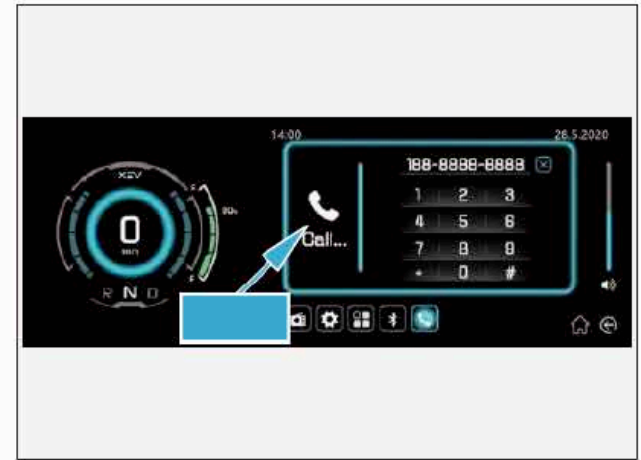
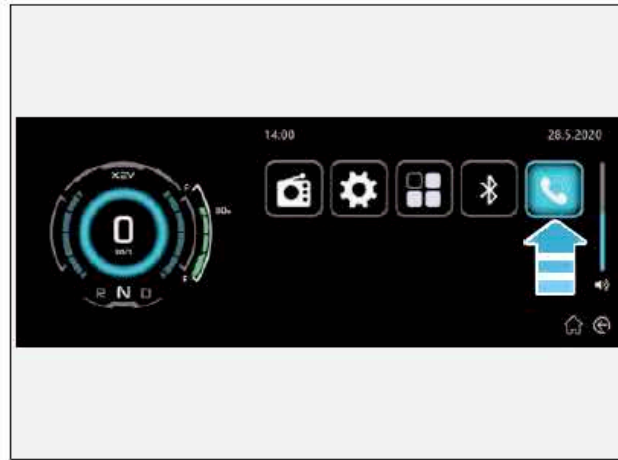

Click **[H]** to enter the Bluetooth setting interface.

If more devices are found, the Bluetooth native Bluetooth name is displayed, XEV2020 and pin number 0000 or 1234.

Use after connecting to Bluetooth.

Dial interface.

The phone searches for the name of Bluetooth and pairs it. After connecting once, it will automatically connect.



Incoming call interface

**⚠ WARNING**

- Keep the car entertainment navigation system and all parts and accessories out of the reach of children.
- Please keep it dry. Rainwater, moisture, and various liquids or moisture can contain minerals that can corrode electrical wiring. If the machine comes into contact with water or is immersed in water, the parts will be damaged, resulting in irreparable damage.
- Do not throw, knock or shake the machine. Rough handling of a machine can damage it.

**⚠ WARNING**

- Do not store the machine in an overheated place. High temperatures can shorten the life of electronics, damage batteries, and cause some plastic parts to warp or melt.
- Do not put the machine in a place that is too cold. Otherwise, when the machine temperature rises or to room temperature, its interior will form moisture, which will destroy the circuit board.
- Do not attempt to disassemble the machine. Non-professional handling of the machine can damage the machine.
- Do not use strong chemicals, cleaning agents, or strong detergents to clean the machine.
- When using or storing machines, keep away from electromagnetic, radioactive, or magnetic equipment.
- Use a soft and clean cloth to wipe the screen, do not use ordinary paper to wipe the screen.
- The LCD screen is easy to scratch, please use the touch pen to do all the operations. Do not damage the screen by using other sharp objects.

Charging device	Instrument & control devices	Lighting device	Safety device	Vehicle device	Starting & driving	Emergency treatment	Repair & maintenance	Technical information
-----------------	------------------------------	-----------------	---------------	----------------	--------------------	---------------------	----------------------	-----------------------

## Start and driving

<b>Driving preparation</b>	72	<b>Parking</b>	81
Run-in period	72	Parking precautions	81
Safety check before driving	72	Emergency stop	81
Precautions before driving	73	<b>Driving in special conditions</b>	83
Correct sitting posture	74	Night driving	83
Check the horn	75	Long distance driving	83
<b>Start driving</b>	76	<b>Driving in special weather</b>	84
One key start	76	Driving in fog	84
Pedal	77	Driving in rain	85
Gear knob	78	Driving in hot weather	86
Parking	79	Driving in cold weather	86
Electric power steering (EPS)	79		
Anti-lock braking system (ABS)	79		

**Run-in period**

In order to ensure the service life of the vehicle, the vehicle should be run in at the beginning of its use before it can be used normally. Special attention should be paid to the driving mode of a new car during the initial 1500km journey, which will help ensure the reliability and economic performance of the vehicle in the future. Before driving the motor to work at the maximum load, its moving parts should be run in. The following should be noted at this stage:

- A new tyre must be run in for optimum adhesion. Drive carefully within the first 500km.
- The new brake plate should also be run in, because the initial 200km will not have the best friction performance, in the braking effect is not the best case, please moderately increase the brake pedal force.

**Do not overload**

Confirm that the loading quality in the running-in period is not up to the maximum load, otherwise it will cause serious damage to the parts that are not up to good running-in.

**Do not drive long distance**

Do not drive long distance during the running-in period, which will cause wear and tear of the driving motor.

**Avoiding emergency braking**

Minimize the number of emergency braking, otherwise the braking system will be impacted, and increase the impact load of the chassis on the driving motor.

**Avoid towed vehicles**

If there is a problem with the vehicle, use a platform or wheel-mounted trailer for transport. Using a towing chain or cable to tow the vehicle may damage the vehicle.

**Initial maintenance**

From the date of purchase of the vehicle, within three months or after driving 3000 km, the vehicle must be the first running-in period maintenance, to ensure that the vehicle is in a good state of use. buono stato.

**Safety check before driving**

It is necessary to have a vehicle inspection before driving. The inspection will help to drive safely and enjoy driving.

**Drive motor before starting vehicle exterior**

Tyres: Check the tires for damage or proper inflation pressure and for foreign bodies embedded in tread lines. Take corrective action if necessary.

Wheel nut: Check whether the wheel nut is loose.

Leakage: parking the vehicle for a period of time, check whether there is leakage of brake fluid or other liquids under the car (dripping after using air conditioning is a normal phenomenon).

Lighting: Check whether the front combination lights, rear combination lights and other lights are working properly.

Body: Make sure all Windows, rearview mirrors and exterior combination lights are clean and not covered.

Charging device	Instrument & control devices	Lighting device	Safety device	Vehicle device	Starting & driving	Emergency treatment	Repair & maintenance	Technical information
-----------------	------------------------------	-----------------	---------------	----------------	--------------------	---------------------	----------------------	-----------------------

**Interior**

On-board tools: confirm that on-board tools are complete.

Seat belts: Check that the seatbelt latch is securely fastened and that the seatbelt is not worn.

Instrument and controller: check whether the instrument and indicator light on the instrument panel are normal.

Brake pedal: Make sure the pedal is back flexibly and has enough operating space.

Spare Fuses: Make sure all types of fuses are available.

**Front cabin**

Battery and cable: check whether the joint is corroded or loose, and whether the battery is cracked. Check that cables and connections are in good condition.

Brake pipeline: check whether there is oil leakage, oil leakage and connection loose.  
 Brake fluid: check whether the level of brake fluid is within the specified range.

**ATTENTION**

- Do not fill the car with a variety of children’s toys, although it is easy for children to play, but it will leave a safety hazard, especially in the event of emergency braking or collision, these toys will not only affect the safety of the road, and is likely to become a weapon to harm children.

**After the drive motor starts**

Instrument: Observe the indicator lights on the instrument and confirm that there is no alarm light and the failure light can be turned on before starting the vehicle.

**In the process of driving**

Instrument: make sure the indicator light on the instrument is working properly.

Brake: Make sure the vehicle does not turn to either side when braking.

Brake power: check whether the brake power is missing.

Other abnormal phenomena: check whether there is abnormal noise or odor.

**Precautions before driving**

- Be sure to familiarize yourself with your vehicle and safe handling methods.
- Adjust seats, seat belts, interior/exterior rearview mirrors, etc.
- Make sure all occupants of the vehicle are strapped in.
- Make sure the door and cabin door are closed.
- Make sure the door lock mechanism is working properly.
- Check the working condition of indicator light and alarm light when starting switch is on.
- Check the connection between the battery terminal and the power harness in the cabin before inspection.
- Check whether the power battery is fully charged.
- When the voltage of the 12V battery is lower than 9V, the whole vehicle may not work properly.

**AVVERTENZE**

- It is forbidden to place mobile phones, pens and hard items on the instrument panel. In case of emergency braking or accident in the process of driving, these items will fly out and cause injury or even death to people.

### Correct sitting posture of driving

Correct driving sitting posture is conducive to driving operation, reduce wrong actions, easy to observe the instrument and road conditions, easy to use a variety of driving control mechanisms, so as to ensure correct, flexible, agile, durable, safe driving operation, to ensure traffic safety.

Correct sitting posture can also reduce the driver's fatigue and maintain the driver's health.

Correct sitting posture can also make the driver feel comfortable.

Correct driving sitting posture can make the driver's hands, feet can be free activities, smooth control of the steering wheel, pedals and buttons and other institutions, reduce the occurrence of accidents.



#### The steps for proper sitting posture are as follows:

- 1 Sit up straight against the back of the seat.
- 2 Adjust the seat back and forth to make sure the pedal is pushed to its lowest position with ease.
- 3 Adjust the seat back to allow easy operation of the various control switches.
- 4 Fasten your seat belt properly.

#### WARNING

- It is prohibited to adjust the seat position while the vehicle is in motion.
- Do not place cushions between the body of the driver or occupant and the backrest.
- Do not place objects under or near your seat.

#### ATTENTION

- The driver should keep his hands on the outer ring of the steering wheel at all times to ensure that he can see all the instruments and indicators on the combined instrument.
- In the process of driving, the seat back should not tilt too much, must correctly wear the seat belt, and maintain the correct sitting posture, in order to prevent injury to personnel caused by emergency braking.

Check the horn

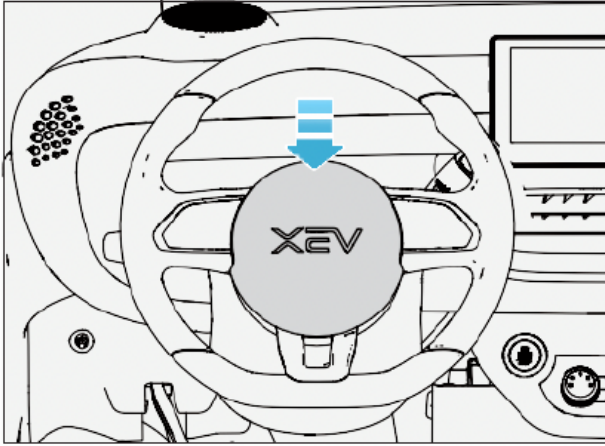

The use of car horn is for the special road section or emergency warning in advance, to ensure traffic safety. When the starting switch is in any position, press the horn cover set on the steering wheel and the horn will beep.

Start / stop

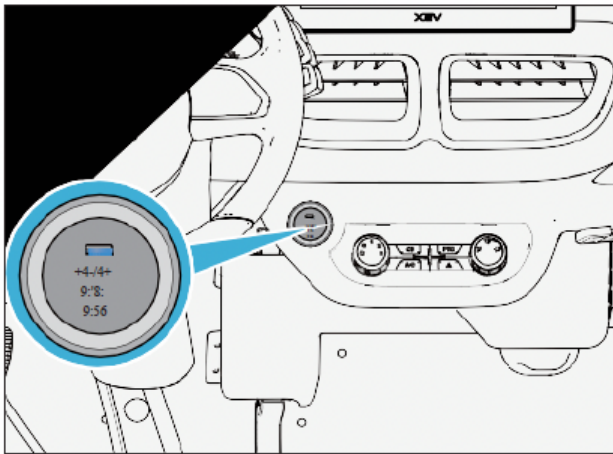

The key start switch has three power states, namely: "OFF" state: the power system is off. "ACC" status: turn on the power of some electrical equipment in the car, such as large touch-screen interactive multimedia screens, etc. "ON" state: turn on the power of all electrical equipment of the car, and the car will start self-checking

<b>⚠ ATTENTION</b>
<ul style="list-style-type: none"> <li>It is normal to hear the light working sound of the vacuum pump for a few seconds when the vehicle is at rest after starting.</li> </ul>

<b>⚠ ATTENTION</b>
<ul style="list-style-type: none"> <li>After the vehicle is powered off, it can be restarted after 5s, otherwise the vehicle may report a malfunction.</li> </ul>

Power state switching

Switch state	Operations
Changed to "ACC"	The power state is "OFF", the remote control key is in the car, press a key to start the switch, and at the same time unlock the electronic Steering column lock.
Switch to "ON"	The power state is "OFF" or "ACC", the gear knob switch is turned to the "N" gear position, the remote control key is in the car, and the brake pedal is not depressed, press a key again to start the opening turn off.
Switch to "OFF"	The power state is "ON" or "ACC", the gear knob switch is turned to the "N" gear position, the foot is on the brake pedal, and the vehicle speed is 0km/h, Press a key to start the switch.

Start function

Step the brake pedal, and the current state is in OFF or ACC or IGN, and press the start button. If a legitimate key is found, the electronic steering column lock will be equipped with ACC electric and unlocks first, and the unlocking state of the electronic steering column lock will be detected. If it is unlocked normally, a signal of "approval of ignition key" CAN be output. IGN distribution output; Then output the high voltage request signal, triggering the high voltage; With a long buzzer, enter the START gear. If the electronic steering column lock is not unlocked successfully, then the signal of "Approval of Ignition Key" remains 0, and no high-voltage request signal is output. The buzzer will beep three times to indicate abnormality.

Emergency stop function

If the current status is in "ON" or "START" status, press the START button again. If the current speed is less than 20km/h, "ACC/IGN" will power down and return to "POW-OFF" status. When the speed is greater than 20km/h, it is necessary to press the start button for 4S before the power is off.



**Start the vehicle**

- Make sure the remote control keys are in the car;
- Confirm that the switch of the gear knob is turned to the "N" gear position;
- Step down the brake pedal;
- Press the start/stop button, at the moment, the "READY" is lit on the instrument.
- Release the parking brake pedal.

**Low power consumption function**

**BCM Dormancy condition**

After the vehicle enters the fortification state, the BCM enters the sleep mode for 2s; When the vehicle exits the fortification state or enters the alarm state, the BCM will enter the normal working state from the sleep mode within 0.2 seconds.

**BCM CAN network Dormancy condition**

- IGN OFF, CAN stops after 10s;
  - The door is closed within 10s, and there is no switch action or remote control command or IGN is opened.
  - The remote control is successfully locked, and CAN sleeps immediately.
  - Other modules of the CAN network do not send CAN messages or commands, and the CAN signal is dormant for 10S.
- BCM wake-up conditions**
- ACC ON (one key start press).
  - Any car door is opened, or an anti-theft alarm is issued.
  - Receive commands or data from other modules on the CAN bus.
  - BCM module wake up request signal received.
  - Remote control to open, lock, remote control to find the car.
  - The emergency switch is down.
  - Open and close Windows by remote control.
  - The brake pedal is down.

Pedal

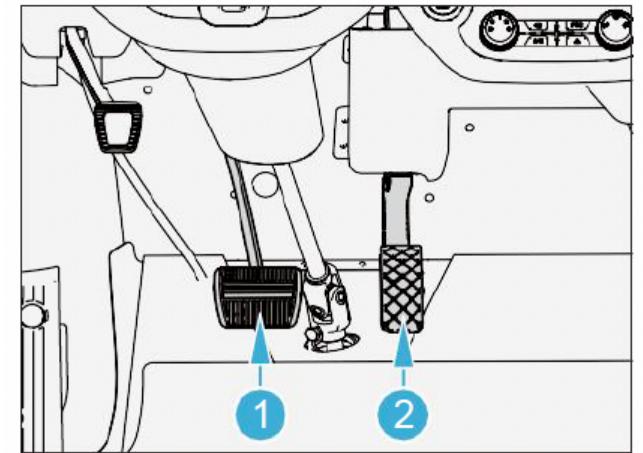

1 brake pedal  
2 accelerator pedal

<b>WARNING</b>
<ul style="list-style-type: none"> <li>• Do not store any items in the driver's foot space. Because the items may slide into the pedal area, hampering the driver's operation of the pedal, emergency braking or in case of emergency, the driver can not operate the brake pedal or accelerator pedal, easy to cause traffic accidents.</li> <li>• Driving in high-heeled shoes is prohibited.</li> </ul>

## Gear knob

**! ATTENTION**

- When the vehicle is running, it is necessary to ensure that all pedals work to get to the bottom without any obstacles and to return freely.
- When the brake system fails, it is strictly prohibited to continue driving, please immediately contact XEV new energy vehicle authorized service station maintenance.
- In the plateau area, the braking power provided by the electronic vacuum pump is decreased. Please drive carefully.
- If the electronic vacuum pump works for a long time, it may be the vacuum booster system leakage. It is strictly prohibited to continue driving. Stop and check as soon as possible and contact the XEV new energy vehicle authorized service station for maintenance immediately.

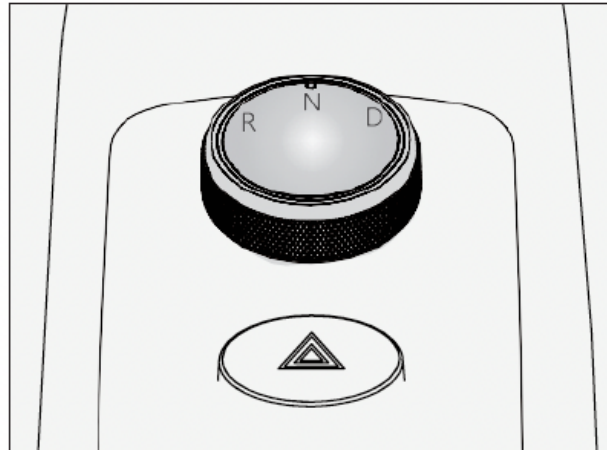

R: Reversing gear  
Turn to this gear when reversing.

N: Neutral  
Turn to this gear if you need to stop temporarily.

D: Driving gear  
Turn to this gear when driving normally.

**! ATTENTION**

- When parking in "R", "N" or "D" gear, you must press the brake pedal. If you need to get off, you must press the parking brake pedal.
- When shifting gears, do not step on the accelerator pedal. After shifting gears, do not immediately step on the accelerator pedal to avoid damage to the transmission.
- When the vehicle is in the forward state, it is strictly prohibited to turn the knob switch to the "R" gear position to avoid damage. Make sure the vehicle stops completely and press on the brake pedal before turning into "R" gear.

## Parking

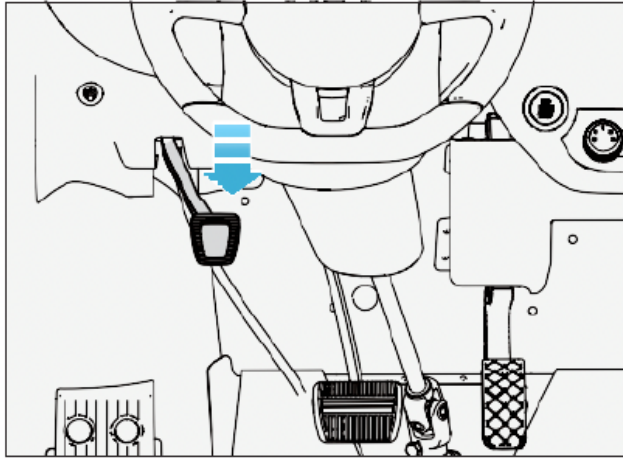

When parking, be sure to use the parking brake pedal. Otherwise, when parked on a slope, the vehicle may slide towards the bottom of the slope.

Set and release the parking brake and press the parking brake pedal. To get a better holding force, press down the brake pedal and hold until the parking brake pedal is pressed down. Push down the brake pedal and then the parking brake pedal.

## Electric Power Steering (EPS)

Electric power steering system is through the motor to power steering, according to the speed, steering torque and wheel steering Angle automatically adjust steering power. The advantages of electric power steering system are simple structure and energy saving. Compared with traditional hydraulic power steering systems, electric power steering systems only require energy during actual steering, which reduces power losses by using electricity on demand. When the starting switch is in the "ON" state, the yellow electric power steering fault warning light EPS is lit for about 2s. If the warning light does not go off after it has been lit or is on during driving, it indicates a malfunction of the electric power steering system.

### ⚠ ATTENTION

- If the electric power steering fails or fails to work, it will become very heavy when turning the steering wheel, which will greatly affect the driving safety. Please contact the XEV new energy vehicle authorized service station for maintenance as soon as possible

## Anti-lock braking system (ABS)

Anti-lock braking system is an important part of automotive active safety system.

### Antilock Braking System (ABS) function

ABS refers to the vehicle emergency braking or in the wet road braking, to prevent the wheel locked (the wheel does not rotate). This device is mainly used to prevent the vehicle from steering failure or tail-slipping phenomenon.

When the anti-lock braking system is in effect, the friction between the wheels and the road is rolling friction, which will make full use of the maximum adhesion between the wheels and the road to brake, thereby improving the braking deceleration speed, shortening the braking distance (in the case of high adhesion coefficient road), and ensuring the directional stability of the car when braking

Anti-lock braking system is equivalent to a high frequency of braking, in an emergency to step on the brake pedal, the driver will feel the brake pedal in the vibration, and accompanied by the operation of the brake pump issued by the "rattle" sound, at this time the anti-lock braking system is in the normal working state.

As the brake main pump is constantly adjusting the brake pressure, there is a continuous feedback force to the brake pedal. Therefore, in this case, be sure to step on the brake pedal in the end, do not step on the brake pedal repeatedly.

Anti-lock braking system is only an auxiliary braking system, whose role is very limited. For example, when braking on gravel road or newly snowed road, the braking distance may be longer than that on cement road or dry road.

It should not be considered that the braking performance of anti-lock braking system can reach the ideal state under any circumstances. Therefore, do not rely too much on anti-lock braking system, only safe driving is the most important.

Do not rely too much on ABS and brake assist device, should control the speed, to ensure the effective distance, to ensure safe driving.

ABS cannot play a role in the case of exceeding the tire lock threshold or water film effect.

Water film effect: when driving at high speed in rainy days, the water film is formed between the tire and the road surface and the grip is lost.

When the starting switch is in the state of "ON", the yellow anti-lock braking system fault warning light ABS is lit for about 2s.

If the warning light does not go off after it is on or if it is on during driving, it indicates that the anti-lock braking system is faulty.

 <b>ATTENTION</b>
<ul style="list-style-type: none"> <li>The stability of the vehicle installed with ABS and the effective control range of the steering wheel have certain limitations, so it can not rely too much on its role, please drive safely.</li> </ul>

 <b>ATTENTION</b>
<ul style="list-style-type: none"> <li>If the anti-lock braking system fails or fails to work, the braking system retains the basic service braking function, but it should contact the XEV new energy vehicle authorized service station for maintenance as soon as possible.</li> </ul>

### Precautions for parking

- Press the brake pedal and slow down to stop.
- Use parking brake as required.

### Emergency stop

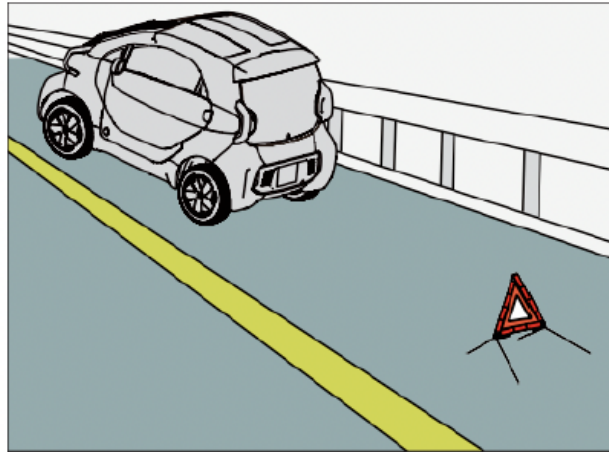

If you have to stop in an emergency, you should choose a section of road with no blind area and stop in the emergency parking zone. Turn on the danger alarm light when it stops. Place a warning triangle at 50~150m (freeway or freeway 150~250m) to remind passing vehicles to pay attention to safety. When passengers get out of the car, make sure you don't open the door until there is no approaching traffic behind you, and do it quickly. Even so, parking on the highway is a dangerous business.

In case of emergency, if it is not possible to stop the car in the normal way, the following steps can be used to stop the car.

- Place your foot firmly on the brake pedal and press it down firmly to avoid stepping on the brake pedal repeatedly.
- After the vehicle has slowed down, stop it at the side of the road in a safe area.

### Precautions for leaving the car

When leaving the vehicle, you should:

- push down the parking brake: page 81
- start/stop button "OFF" gear: page 78
- close all car windows: page 38
- lock the car door: page 35



**⚠ ATTENTION**

- Do not park the vehicle on the top of combustible materials such as hay or gasoline, so as to avoid the ignition of these materials by the driving motor at high temperature and cause a fire.
- When leaving the vehicle, do not leave children or disabled persons alone in the vehicle. In different weather conditions, the car temperature may be very high or very low, easy to make the occupants of the car sick or even death.

Do not park vehicles around flammable materials.

### Night driving

Driving at night should pay attention to the following points:  
 Driving at night is more dangerous than driving in the daytime.  
 One reason is problems with night vision and fatigue.

- Drive carefully.
- Don't drink and drive.
- Adjust the interior and exterior rearview mirrors to reduce the glare of rear vehicle lights.
- Keep distance with other vehicles.
- Slow down when driving, especially when driving in the high speed lane, the lights can only shine on the limited road ahead.
- When driving in remote areas, watch out for animals.
- If you feel tired, pull over to a safe place by the side of the road to rest.
- When encountering dazzling glare, if the driver of the other side does not change the high beam into the near light, he/she should slow down and avoid looking directly at the lights of the opposite vehicle.
- Keep the front windshield and all glass inside and outside surfaces clean. Smudging glass will aggravate nightlight glare.

### Driving for long journey

Make sure you are prepared before a long journey and try to get as much rest as possible.

#### Check the following parts of the vehicle before driving long distances:

- Check that the washing liquid is sufficient and that all Windows are clean, inside and outside.
- Check whether the wiper blade is in good condition.
- Check whether the electric quantity is sufficient.
- Check whether the lights are working properly.
- Check whether the tread pattern is suitable for long-distance driving and whether the tire pressure reaches the specified pressure value.
- For long distance driving, please pay attention to driving distance and charging condition.



### Driving in fog

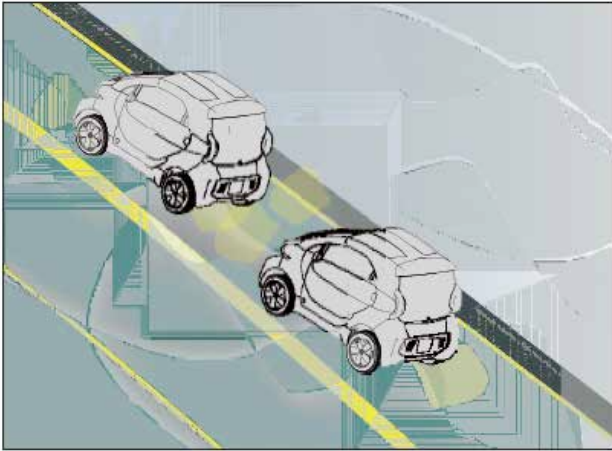

Fog driving visibility is low, please follow the fog driving precautions, to ensure the safety of others and yourself.

**⚠ DANGER**

- In foggy weather, avoid driving vehicles to travel, because of the low visibility of driving road in foggy days easy to cause traffic accidents, causing personal injury or even death.

**⚠ ATTENZIONE**

Precautions for driving in foggy weather:

- When driving in foggy weather, pay attention to control the speed, and do not drive at more than 100 km/h. It is recommended that when visibility is less than 500 meters and more than 200 meters, the speed should not exceed 80 kilometers per hour;
- When visibility is less than 200 meters and more than 100 meters, the speed shall not exceed 60 kilometers per hour;
- When the visibility is less than 100 meters and more than 50 meters, the speed shall not exceed 40 kilometers per hour;
- Visibility within 30 meters, the speed should be controlled below 20 kilometers;
- General visual distance of about 10 meters, speed control in 5 km below.
- When driving in foggy days, try to drive in the middle of the road, do not drive along the roadside, in case of accidentally colliding with the roadside vehicles that temporarily stop and wait for the fog to clear.

**⚠ ATTENZIONE**

Precautions for driving in foggy weather:

- Fog driving before the vehicle should be a comprehensive inspection of the vehicle's lighting device, when driving on fog lights, position lights and light, the use of light to improve visibility, see clearly ahead of the vehicle and pedestrians and road conditions, but also let others easily see the location of their vehicles. At the same time, driving on foggy days is forbidden to use high beams.
- When driving in fog, it is forbidden to step on or loosen the accelerator pedal sharply, not to speak of emergency braking and sharp turn of the steering wheel. If it is necessary to reduce the speed, first slowly loosen the accelerator pedal, and then gently step on the brake pedal, to achieve the purpose of controlling the speed and prevent the occurrence of rear-end collision accident.



Driving on rainy days



When it rains, drive with caution due to reduced visibility, foggy windows and slippery roads.

**▲ PERICOLO**

- When driving in rainy weather, drive at a low speed. In rainy days, traffic accidents occur easily due to poor visibility and slippery road surfaces, resulting in personal injury or even death.

**⚠ ATTENTION**

- When it starts to rain, you should slow down and drive at a low speed because the road becomes slippery.
- When it rains, the outside rearview mirror should be cleaned in time to prevent the raindrops on the rearview mirror from causing the driver's blind spot.
- In cloudy days, heavy rain and fog, poor visibility of rainy days, should be timely on fog lights, near light lights, display lights and front and rear position lights, and control the speed.
- When driving in rainy days, do not slam on or loosen the accelerator pedal, not to mention emergency braking or sharp turn of the steering wheel. If you must slow down, slow down first Accelerate the pedal, and then gently step on the brake pedal, to achieve the purpose of controlling the speed, to prevent the occurrence of rear-end crash.
- When the rain is too heavy or there is thunder and lightning can not continue to drive, the vehicle should be parked in a position without water, to prevent the vehicle from being soaked, and open the danger alarm light to attract the attention of the rear vehicle.

**⚠ ATTENTION**

- After rainy days, the vehicle should be cleaned in time to prevent acid substances in the rain from corroding the body paint.
- When the vehicle wading depth is less than 150mm, the speed is less than 33km/h; When the wading depth is less than 300mm, the velocity is less than 5km/h.

### Driving in hot season

When driving a vehicle in summer, please follow the summer driving precautions to ensure the safety of others and yourself.

<b>⚠ ATTENTION</b>
<ul style="list-style-type: none"> <li>• For the safety of summer driving, always check the tire pressure. With the temperature and road temperature gradually rising, high speed or long distance driving, tire pressure is easy to rise, causing a flat tire.</li> <li>• Wearing slippers while driving a vehicle is prohibited.</li> <li>• Summer driving should not be long time on the air conditioning. Should be appropriate to adjust the working state of the air conditioning, or every period of time to open the window ventilation.</li> <li>• The summer weather is hot, should often check the vehicle line is short circuit or aging, plug is loose, the battery is in normal working state. Prevent vehicle spontaneous combustion.</li> </ul>

<b>⚠ DANGER</b>
<ul style="list-style-type: none"> <li>• It is forbidden to expose the vehicle to the sun for a long time in hot summer, and it is forbidden to place flammable substances (such as lighters, paper scraps, cloth toys, etc.) in and near the dashboard of the vehicle.</li> </ul>

### Driving in cold season



When driving a vehicle in winter, please observe the winter driving precautions to ensure the safety of others and yourself

<b>⚠ DANGER</b>
<ul style="list-style-type: none"> <li>• The driving environment in winter is more dangerous than in other seasons. When driving, you should be extra careful and reduce your speed to avoid accidents that may lead to personal injury or even death.</li> </ul>

**⚠ ATTENTION**

- Before driving in winter, you must carefully check the safety equipment on the car: steering, braking, lights, instruments, horns, wipers, etc., to be complete and effective.
- Drivers must pay great attention to the driving safety under the special weather in winter, improve the safety driving awareness; Concentrate on driving, control speed, and drive correctly.
- In winter, the road is slippery after snow. When driving, pay attention to the smooth speed and even operation. It is forbidden to accelerate sharply, brake pedal sharply and turn suddenly. Stable acceleration in driving, medium and low speed driving.
- In the start and acceleration lightly and slowly, to prevent the occurrence of tire skid and sideslip phenomenon.

**⚠ ATTENTION**

Notes for parking in snow days:

- Park the vehicle in a place without snow or water to prevent water from forming ice and tearing the wheels and tires.
- Place boards on the tire to prevent snow.
- Avoid placing the vehicle under a tree, which is easy to be damaged by falling ice.
- Raise the wiper after parking to prevent it from freezing on the windshield, so as to avoid tearing the wiper during use.
- Wipe the snow water on the combined lamp to prevent freezing and cracking.
- Try to park on flat ground.
- When parking, open the door and cool down for a few minutes, then lock the door, reduce the temperature difference between inside and outside the car, and prevent the glass from icing.

**Check the condition of battery and cable**

Cold weather will reduce the energy of the battery, so the battery should be kept full of power for winter starting.

When mechanical parking brake may freeze, not recommended to drive the vehicle immediately, must wait for parking.

**Prevent ice and snow from accumulating under the mudguard**

hand brake of vehicles, suggested that winter night when parking for a long time and was surrounded by water or snow, application block is blocking the wheels, please do not use the parking brake, so as to avoid parking brake wire surrounded by water, or frozen snow, as a result, the parking brake is difficult to release. Prevent ice and snow from accumulating under the fender. Ice and snow accumulating under the fenders can make it difficult for vehicles to turn. When driving in cold winter, you should always stop and check whether there is snow and ice under the fender.

**Have a spare tool**

Keep some spare tools ready for use in case of emergency. The following equipment is recommended: anti-skid chain, window scraper, sandbag, signal flash device, etc.

Charging device	Instrument & control devices	Lighting device	Safety device	Vehicle device	Starting & driving	Emergency treatment	Repair & maintenance	Technical information
-----------------	------------------------------	-----------------	---------------	----------------	--------------------	---------------------	----------------------	-----------------------

## Emergency treatment

<b>Emergency treatment</b> _____	89	Towing _____	92
Hazard warning lamp _____	89	Hual and reflective vest _____	95
<b>Incident treatment</b> _____	90	Replace fuse _____	96
Vehicle can't start _____	90	Ispecification for fuse of instrument distribution box ____	98
Vehicle trapped _____	90		
<b>Settle by oneself</b> _____	91		
Flat tyre _____	91		
Use of a warning triangle _____	92		

## Hazard warning light



Use hazard warning lights if the vehicle malfunctions or there is a traffic accident. Press the hazard alarm light switch and all turning signals flash. Press the hazard alarm light switch again and all turning signals are off.

Turn on the hazard alarm light in case of the following situations:

- When you temporarily stop on the road.
- When there is a breakdown on the road or a traffic accident.
- When driving on foggy days on general roads.
- On the highway, in the case of fog, rain, snow, dust, hail and other conditions, low visibility is less than 100m.
- When pulling a faulty motor vehicle.

### The vehicle cannot start

If the correct starting procedure for the vehicle is followed but the vehicle is not started, the following reasons should be considered:

- Power battery runs out.
- Drive motor failure. The positive and negative joint of the battery is loose or the battery power is exhausted.

If the powertrain has no power output while driving, operate as follows:

- Reduce your speed slowly, keep in a straight line, and steer off the road carefully to a safe place.
- Turn on the hazard alarm lights.
- Try to restart the vehicle.

### The vehicle is trapped



If the vehicle is stuck in a place such as sand, mud or snow, please do the following:

- Power off the drive motor and press down the parking brake pedal.
- Remove mud, snow or sand trapped around your tires.
- Place blocks of wood, stone or other material to help increase tire friction.
- Restart the vehicle and accelerate carefully to get the vehicle out of the pit.

#### WARNING

- If the vehicle is driven out of the pit by means of front and rear push, ensure that the surrounding area is spacious and unblocked to avoid hitting other vehicles, objects or people. As the vehicle is about to exit the pit, it may suddenly accelerate forward or backward. Be sure to pay attention to the surroundings of your vehicle.

#### ATTENZIONE

In order to prevent damage to the motor and other components, the following precautions must be observed when pushing the vehicle:

- It is forbidden to shift gear when pressing down the accelerator pedal.
- If the vehicle is still unable to get out of the pit after several pushes, a tow truck is needed for rescue.

## Flat tire

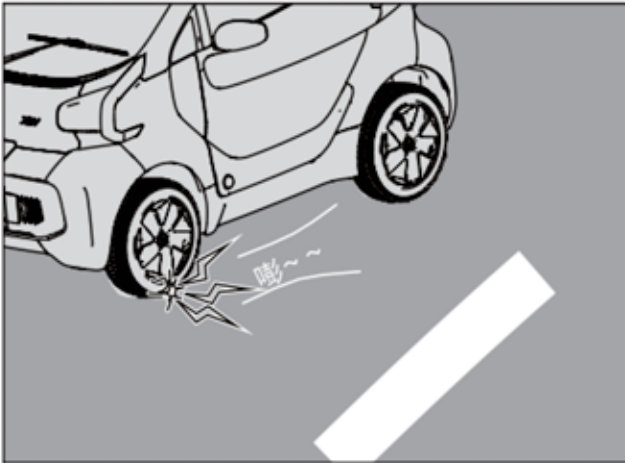

**▲ DANGER**

- When the vehicle is aware of the tire blowout, you should hold the steering wheel with both hands and try your best to control the steering wheel not to rotate by itself, so that the vehicle drives in a straight line along the original direction.
- Do not push the brake pedal hard, otherwise it may cause the vehicle to lose its center of gravity and lose control or overturn.
- Gently step on the brake pedal, slow down slowly, and park the car beside the road. Turn on the danger alarm light in time and place the warning triangle in the rear of the vehicle in accordance with the regulations to avoid the collision of the rear car.

When a tire burst occurs in the process of driving, the vehicle should stop according to the following points for attention. After parking, please contact XEV new energy vehicle authorization service station as soon as possible.

## Preventive measures for flat tire

- Check the tire regularly to eliminate the hidden trouble of tire burst.
- Often remove stones or foreign bodies in the tread pattern grooves, so as not to deform the tire crown.
- Inspect tire side for scratches, punctures, and excessive wear.
- For vehicles often driving on expressways, tire transposition should be carried out every 10 000 km.
- All tyres should be used within their service life. Tyres that have exceeded their service life or have been seriously worn should be replaced in time.

Charging device	Instrument & control devices	Lighting device	Safety device	Vehicle device	Starting & driving	Emergency treatment	Repair & maintenance	Technical information
-----------------	------------------------------	-----------------	---------------	----------------	--------------------	---------------------	----------------------	-----------------------



### Use of warning triangle



 <b>ATTENTION</b>
<ul style="list-style-type: none"> <li>Please use the warning triangle correctly according to the corresponding national laws and regulations.</li> </ul>

The warning triangle is located under the cover of the trunk.

When you have a problem with your car and need to pull over to the side of the road, please place a warning triangle at the back of the car to warn you of coming behind

The correct distance to place the warning triangle		
	daytime	night time
City loop	50 m	150m
Expressway, highway	150m	250m



## Towing

### Before towing

The following situations indicate a possible malfunction of the vehicle. Please contact XEV new energy vehicle authorization service station before towing the vehicle.

- The motor runs normally, but the vehicle cannot move.
- The vehicle makes an abnormal sound.

### Towing mode

- If the vehicle needs to be towed, it is recommended to use a wheel-lifted trailer or a platform trailer, and it is recommended to be towed by the corresponding XEV new energy vehicle authorized service station or a professional towing company.
- If the wheels and axles of the vehicle are in good condition, it can be towed by a wheel-lifting trailer.
- When towing, attention should be paid to avoid the rear wheel rolling with the trailer.

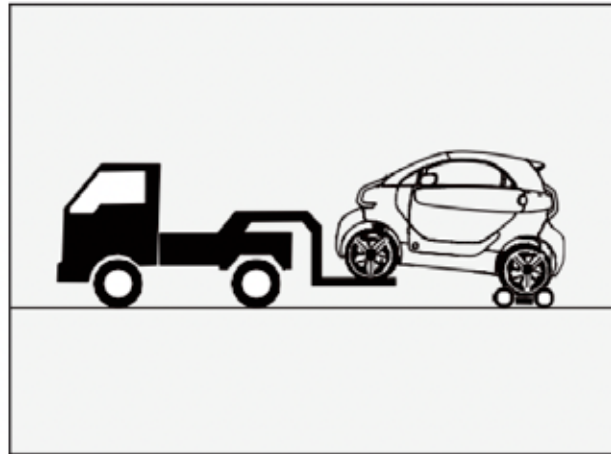

Towing with a wheel trailer

When towing a vehicle from the front of the vehicle with a wheel trailer, use a towing trolley under the rear wheels and secure it.

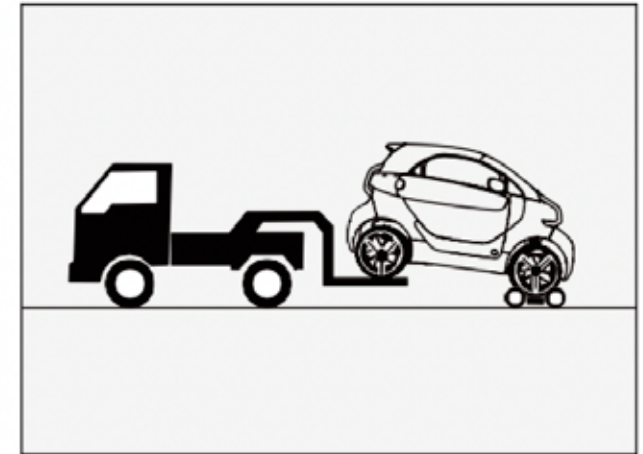

When towing a vehicle from the rear of the vehicle with a wheel-lift trailer, it is necessary to use a towing trolley under the front wheels and secure it

#### ⚠ ATTENZIONE

- All towing shall be done using a safety chain system and in compliance with all national/ provincial (municipal) and local laws and regulations

#### ⚠ ATTENTION

- When lifting the vehicle, make sure there is sufficient clearance at the landing end of the vehicle. Otherwise, the vehicle may be damaged during towing.
- Do not drag from the rear of the vehicle with the start switch in the "OFF" position, as the steering mechanism is locked and the front wheels will not be kept straight.

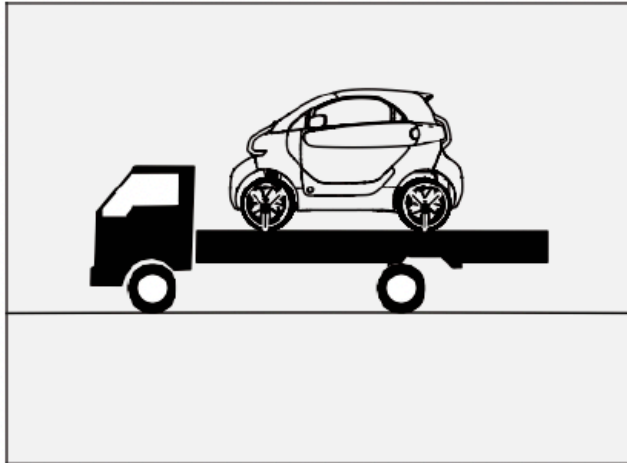

Use a platform trailer

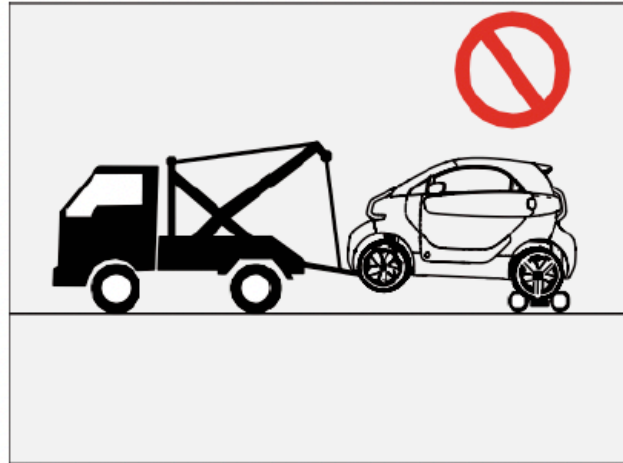

Do not use a lift trailer for towing

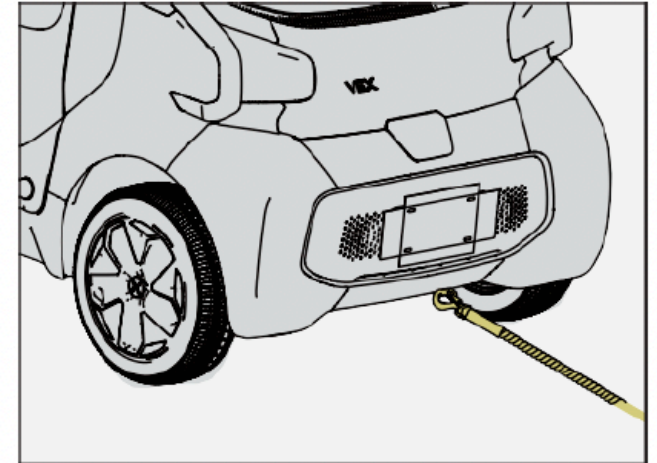

If in an emergency situation can not find a lift trailer or platform trailer, you can use a traction chain or cable to fasten the front of the car in the trailer hook, temporary traction vehicle.

This method is only suitable for low speed and short distance traction on hard pavement.

**⚠ WARNING**

- Emergency traction can only be used when the wheels, axles, steering wheel and brakes are in good condition.
- When towing the vehicle, the danger alarm light switch of the towing vehicle and the towed vehicle should be turned on.
- After meeting the above conditions, the driver must sit in the car to control the steering wheel and brake pedal, to avoid causing injuries and vehicle damage in the traction process.
- It is forbidden to drive at high speed when pulling the vehicle.
- Inexperienced drivers should not attempt to pull other vehicles to avoid accidents.
- When towing the vehicle, the braking booster and steering booster of the towed vehicle do not work.
- Brake before the normal situation should be braking, but should tread on the brake pedal gently

**Traction requirements**

- Shift the shift lever into neutral.
- Do not pull at a speed higher than 30km/h.
- The maximum traction distance is 50km.

**⚠ WARNING**

- Avoid sudden start or erratic driving during traction.
- In traction, avoid the traction distance between vehicles is too close.

**⚠ ATTENTION**

- If the traction vehicle is difficult to move, it is prohibited to continue the traction forcibly. You should contact XEV new energy vehicle authorization service station for assistance.
- Vehicle traction should try to maintain a straight line traction..

**Reflective vest**



This model is equipped with a “reflective vest”, when the car in the night, dusk, rain and fog and other low visibility failure or other accidents, need to wear the “reflective vest” its purpose is to improve the visibility of the driver to get off on the road action, to prevent the accident again.

## Replace the fuse

The fuse itself fuses when the electrical equipment is overloaded to cut off the current to protect the electrical equipment of the car.

If any electrical equipment does not work, the corresponding fuse may be blown, the fuse should be checked and replaced if necessary. Replace the fuse with a new fuse with the same rated current value.

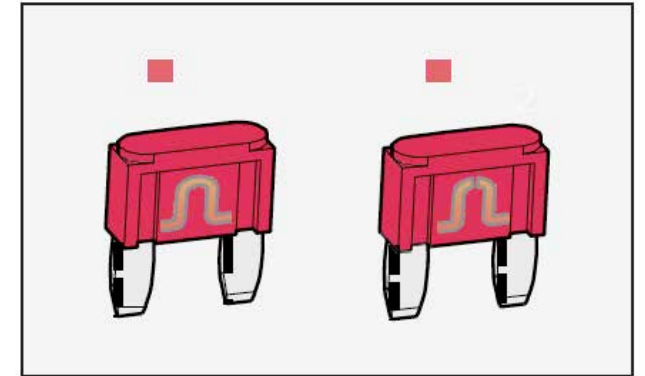
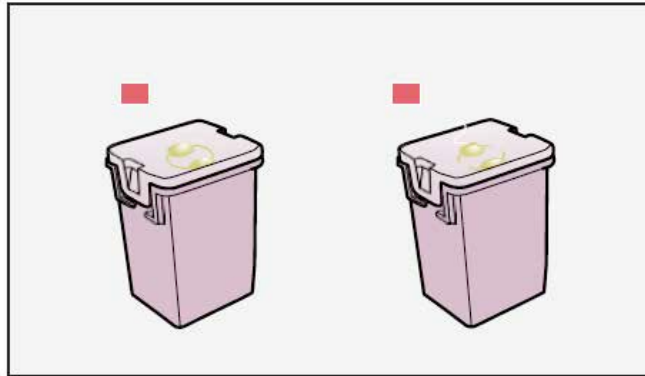

### Slow fuse

1 normal fuse  
2 blown fuses

### Quick fuse

1 normal fuse  
2 blown fuses

**WARNING**

- Do not use metal sheet instead of fuse. It is strictly prohibited to use the rated current value higher than the specified value of the fuse, otherwise it may damage the electrical equipment. The color and logo of the replaced fuse must be exactly the same as the original fuse. The inside of the distribution box must be kept clean and moisture-proof.

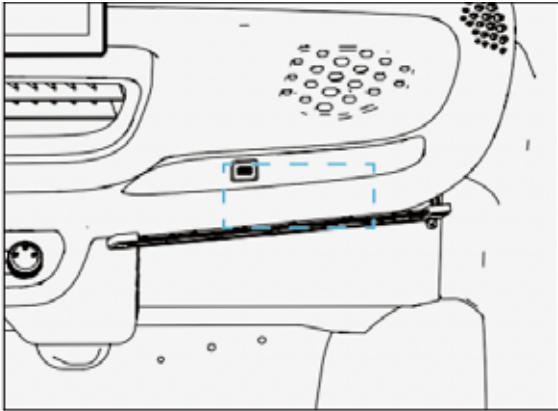

### Instrument distribution box

The instrument distribution box is located in the lower right side of the instrument panel inside the guard plate, the relevant accessories need to be removed during inspection.

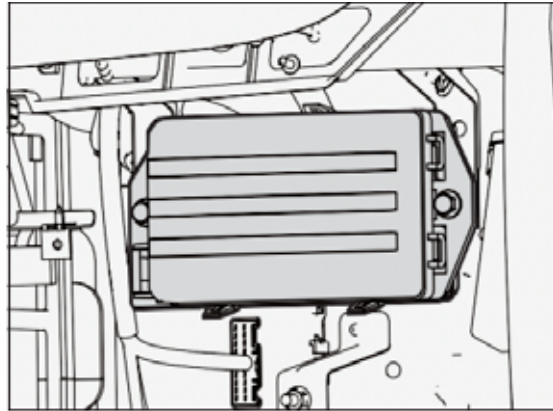

Press the fuse box lock tongue to open the fuse box.

Specification for fuse of instrument distribution box

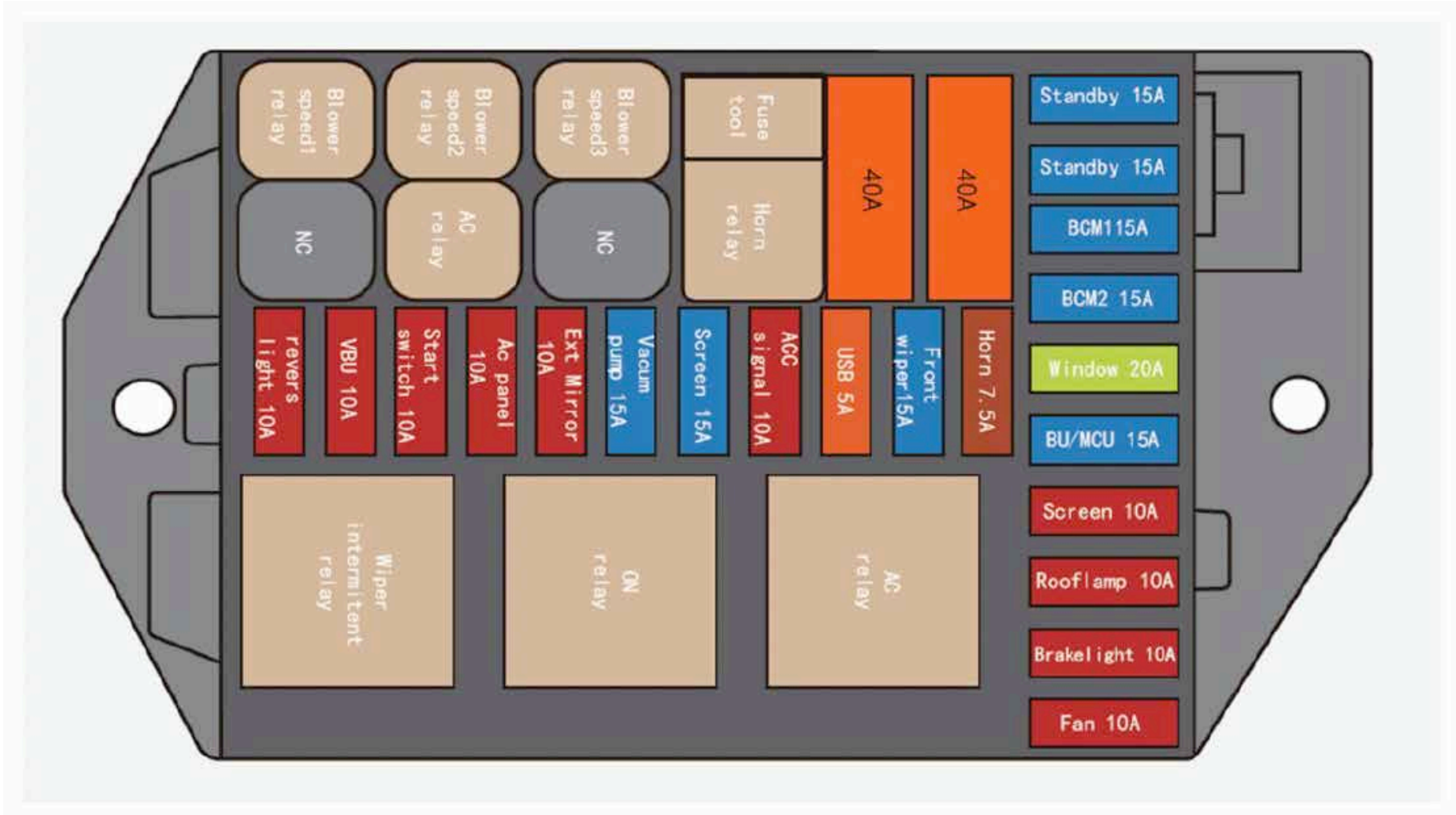

Charging device	Instrument & control devices	Lighting device	Safety device	Vehicle device	Starting & driving	Emergency treatment	Repair & maintenance	Technical information
-----------------	------------------------------	-----------------	---------------	----------------	--------------------	---------------------	----------------------	-----------------------

N.	rated current	A protected component or electrical appliance
1	15A	standby
2	15A	standby
3	15A	BCM1
4	15A	BCM2
5	20A	Window
6	15A	BU/MCU
7	10A	Screen
8	10A	Rooflamp
9	10A	Brakelight
10	10A	Fan
11	7,5A	Horn

N.	rated current	A protected component or electrical appliance
12	15A	Frontwiper
13	5A	USB
14	10A	ACC signal
15	15A	Screen
16	15A	Vacumpump
17	10A	ExtMirror
18	10A	AC panel
19	10A	Start switch
20	10A	VBU
/	10A	Revers light
/	40A	reserved

N.	rated current	A protected component or electrical appliance
/	40A	reserved
/	/	Blower speed relay3
/	/	Blower speed relay2
/	/	Blower speed relay1
/	/	Fuse tool
/	/	Horn relay
/	/	NC
/	/	AC relay
/	/	NC
/	/	AC relay
/	/	ON relay

N.	rated current	A protected component or electrical appliance
/	Frontwiper	Wiper intermittent relay



## Repair and maintenance

<b>Regular maintenance</b> _____	102	Replacement tires _____	108
Instructions for regular maintenance _____	102	The wheel transposition _____	109
Self-maintenance instructions _____	102	Tyre chain _____	109
<b>Brake fluid</b> _____	103	<b>Windshield wipers and scrubbers</b> _____	110
<b>Battery, power battery</b> _____	104	Windwindow washing liquid, scrubber nozzle _____	110
Battery _____	104	Wiper blade _____	110
Power battery _____	105	<b>Cleaning and vehicle maintenance</b> _____	111
<b>Tyre</b> _____	106	External vehicle maintenance _____	111
Tyre inspection _____	106	Internal vehicle maintenance _____	114
Tyre wear mark _____	108		

### Precautions for regular maintenance

After driving for a long time, the friction surface of the moving parts will wear and tear, and the working conditions of the systems and components will also change. In order to ensure that the vehicle is in a good state of use, regular maintenance must be carried out according to the provisions of the Maintenance Manual. It needs to be noted that the maintenance cycle is based on the normal driving conditions of the vehicle. If the vehicle is driven under harsh conditions for a long time, the maintenance times of several maintenance items should be increased according to the actual situation, or the maintenance cycle should be shortened.

#### The following are adverse conditions:

- Driving in dusty areas or cars are often exposed to salty air or salt water.
- Driving on the road where the water exceeds the chassis or on the bad mountain road.
- Frequent use of brake and emergency brake.
- Use as a taxi or self-driving rental car. Overload driving.

### Precautions for self-maintenance

In addition to regular maintenance, the owner should also often carry out some simple checks.

#### Daily check

- Functions of lights, horns, windshield wipers, scrubbers and warning lights.
- Function of seat belt and brake.
- Check the underbody for traces of fluid that could indicate a leak.

#### Weekly check

- Brake fluid level.
- Windscreen washing liquid level.
- Tire pressure and state.
- Air conditioning system operation.

**ATTENTION**

- In the vehicle maintenance work, if you need to replace parts, it is recommended to XEV new energy vehicle authorized service station to choose genuine parts, the use of fake and shoddy products is strictly prohibited.

**WARNING**

- For your safety, please read and follow all usage instructions printed on labels and containers.

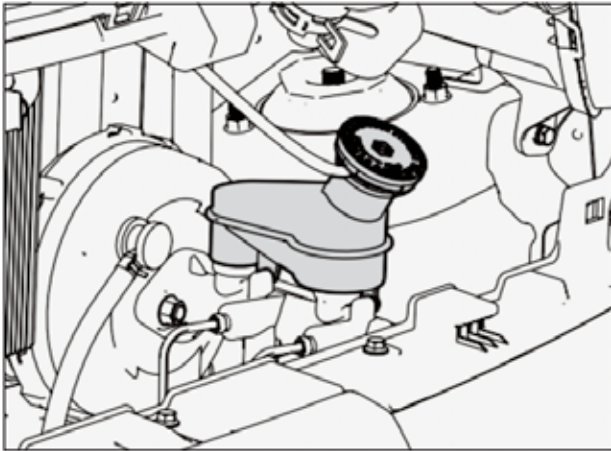

If the brake fluid level in the liquid storage pot is between the marked lines "L" and "H", the brake fluid level is normal. If the liquid level is below the "L" mark, open the lid of the brake fluid storage pot and add the brake fluid. However, the liquid level should not exceed the "H" mark.

Please use the brake fluid recommended and approved for XEV new energy vehicles. Please refer to page P131 for specifications and dosage.

Brake fluid replacement cycle: two years or 40,000 kilometers, whichever comes first.

**⚠ WARNING**

- If brake fluid splashes on skin or eyes, rinse immediately with plenty of water..

**⚠ ATTENTION**

- When checking the brake fluid, the vehicle should be parked on the flat ground, and the vehicle must be in the cold state.
- Brake fluid will corrode the paint surface, avoid splashing brake fluid on the car body. If the brake fluid splashes on the body of the car, wipe it off with a good absorbent cloth and clean the area with water or cleaning agent.
- If the brake fluid level drops significantly in a short period of time, there may be leakage or fault in the brake system. Please contact the XEV new energy vehicle authorized service station for maintenance in time.

Battery

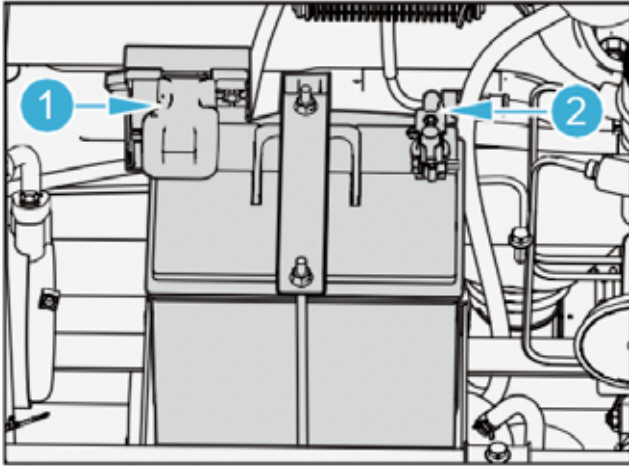

Open the front cabin and you can see the battery. The battery is of maintenance-free type.

Regularly check the surface of the battery and the positive and negative terminals for no loosening or corrosion.

1 the positive  
2 the cathode

**⚠ ATTENTION**

- When the vehicle is parked for a long time, it is recommended to disconnect the negative cable of the vehicle battery to avoid excessive discharge of the battery. Before connecting or disconnecting the negative cable of the vehicle battery, make sure the start switch is off.
- Do not use vehicle-mounted electrical appliances for a long time in the state of vehicle flameout, otherwise it may cause serious battery loss and can not start.
- When replacing the battery, it is only limited to the same specification battery. It is recommended to replace it at the XEV new energy vehicle authorized service station.

**⚠ ATTENTION**

- When the battery is working, it produces flammable and explosive hydrogen gas.
- When using tools, do not let the battery produce sparks.
- Do not smoke or light matches near the battery.
- Safety goggles should be worn when working near the battery.
- Keep children away from the battery.

### Power battery

The power battery used in the vehicle is a lithium-ion power battery pack, which is composed of lithium iron phosphate monomer cells in series and parallel.

- The minimum termination voltage of discharge is 60V, the maximum limit voltage of charge is 87.6V, the standard charging current is 25A, the discharge current lasts less than 100A, the maximum instantaneous discharge current is less than 250A 10s, the operating temperature range is 0 ~ 45, the operating temperature range is -10 ~ 50. Storage ambient temperature range -10 ~ 45, 75%RH.
- It is not allowed to place the power battery near a high temperature heat source. The vehicle should be kept dry, avoid long time in the wet environment parking, such as: water parking lot, etc. If the vehicle is immersed in water or wading (wading depth is not more than 100mm), it should be parked in a dry place. Power battery leakage, if the electrolyte or powder drops splash on the skin or eyes, should immediately wash with plenty of water, and immediately to the hospital for treatment.

- Unexpected accidents such as fluid leakage and smoke may occur when the
- power battery is not used correctly or impacted. When the power battery is smoking, evacuate the nearby people, immediately use the fire extinguisher, do not spray with water or soak it in water.
- The power battery is located in the chassis position, scratch, collision is easy to damage, so the vehicle on the abnormal road surface, need to contact XEV car service station in time, check whether there is deformation of the battery, shell crack, etc.
- In case of serious accident, after the accident is handled, please contact XEV car service station for timely inspection.
- Power battery needs to go through 30~40
- complete charging and discharging cycles (full discharge) to reach the best performance state. In order to prolong the service life of power battery, it is recommended to observe this operation.
- Tire pressure and state.
- Air conditioning system operation.

 <b>ATTENTION</b>
<ul style="list-style-type: none"> <li>• Use the vehicle at least once a month and charge the vehicle to ensure the power battery life. When the vehicle is not in use for a long time (more than 3 months), ensure that the power battery is stored at about 50%, and the vehicle is not allowed to park for more than 1 month when the power battery is less than 30%. XEV company shall not be liable for any damage to the power battery or related components caused by the user's failure to use or store the battery as required.</li> </ul>

## Tyre inspection

### New tyre

The new tyre has not yet formed the best adhesion ability at the beginning of use, in order to extend the service life of the tyre, in the first three months should be at a moderate speed and the correct way of driving "running-in". Due to structural characteristics and tread design, the tread depth of different new tires will be different. When a vehicle passes a curb or similar obstacle, it should travel as slowly as possible in the vertical direction of the obstacle.

Do not contact the tyre with grease, oil and fuel. Inspect your tires regularly for damage (e.g. cuts, cracks, or bumps) and remove any debris embedded in the tire pattern.

Hidden damage of tires and rim damage is often not easy to be found, if the vehicle is found to be abnormal vibration or deviation, indicating the existence of a tire fault, at this time should go to the XEV new energy vehicle authorized service station as soon as possible to check the tire.

### Tyre life

Tires more than 6 years old, even if rarely or never used or without obvious damage, must be inspected at the XEV new energy vehicle authorized service station.

#### ATTENTION

- In the initial 500km, the road adhesion of the new tyre cannot reach the best state, so the vehicle should be driven at a moderate speed and carefully to prevent accidents.
- If the tyre pressure becomes low during driving, do not continue driving, otherwise the tyre and/or wheel may be completely damaged.
- To ensure your driving safety, please tighten the tyre nut after driving for 6 months.

### Tyre pressure

The tyre inflation pressure is related to the tyre temperature. When the vehicle is in motion, the tyre heat will be generated and the tyre inflation pressure will increase. Therefore, the tyre inflation pressure can only be corrected when the tyre temperature is basically the same as the ambient temperature.

#### WARNING

- Do not correct the tyre inflation pressure when the tyre temperature is too high. Otherwise, the tyre may be seriously damaged or even burst, causing an accident.
- Driving at high speed for a long time will make the tyre with low inflation pressure frequently deform and squeeze, which will make the tyre become overheated, which may lead to the tyre pattern crack or even burst, thus causing an accident.

### Check tyre air pressure

- Unscrew the valve cap.
- Attach the barometer to the valve mouth.
- Check the tire pressure. When checking the tire pressure, the tire must be in the cold state. When the temperature rises, the pressure is slightly higher than the specified pressure, but it is not necessary to lower the tire pressure.
- Adjust tire pressure according to vehicle load. Check whether the tire of the wheel meets the specified tire pressure.
- Install and tighten the valve cap.

Driving a vehicle with incorrect tire pressure can cause the following consequences:

- Excessive tire wear.
- Reduced driving comfort and shortened tire life.
- Reduced security.
- Drive train damage.



### WARNING

formance. Check tire pressure at least once a month and before long trips. Incorrect tire pressure can occur in the following situations and cause accidents that can lead to serious injury or even death.

- Excessive wear
- Uneven wear
- Poor handling
- The tire overheated and blew out
- Wheel deformation
- Damaged due to bad road conditions.



### Tire wear mark

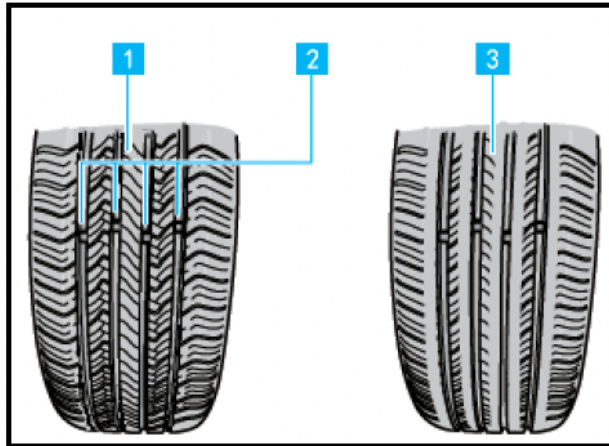

According to the maintenance plan and tire wear condition, replace the tire or tire transposition.

When the tire is worn to the wear mark, the tire must be replaced, otherwise it may lead to an accident.

- 1 New tire tread
- 2 Tire wear marks
- 3 The worn tread of the tire
- 4 The position of the tire wear mark is indicated by "□"
- 5 Molded to the side walls of each tire.

### Change of tire

The tire should be replaced under the following circumstances:  
The tires need to be replaced when there are cuts, breaks, deep cracks exposed to the curtain layer and bumps inside the tires that are damaged.

Replacement of a tire is necessary when the tire often leaks air, suffers cuts, or suffers other damage that is beyond repair.

If you are not sure whether you need to change your tires, please consult the XEV New Energy Vehicle Authorization Service Station.

**⚠ ATTENTION**

- Do not continue driving if the air pressure of each tire decreases while driving, otherwise it may result in complete tire and/or wheel damage.
- Long-term driving on the uneven road surface is easy to damage tires. Check your tires regularly to prevent driving hazards caused by bruising and bulging of the wheel rim.
- Overload operation of the vehicle should be avoided to cause damage to the wheels or tires. If the tire tread has cracks, aging and other signs or has been used for more than 6 years, you should contact the XEV new energy vehicle authorization service station for inspection in time.

**⚠ ATTENTION**

- Please use tyres with the same specifications as the original tyres, otherwise it may adversely affect the drivability of the vehicle.
- Do not replace a single tire, at least two tires on the same axle should be replaced at the same time.
- After changing the tire, it is necessary to check the dynamic balance of the wheel.



## The wheel transposition

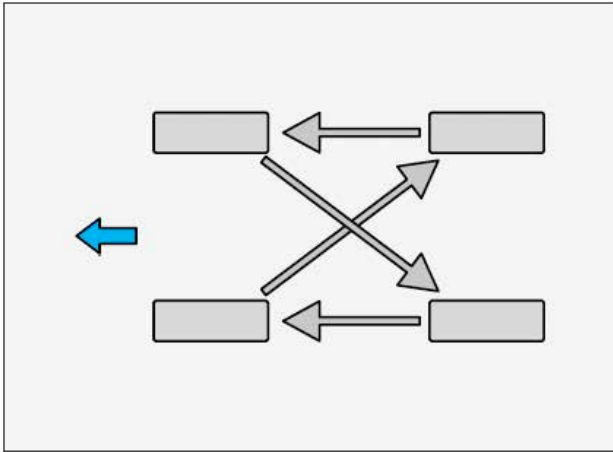

In order to avoid uneven tire wear and prolong the service life of tires, tire transposition should be carried out after the vehicle travels 10000 km. After transposition, adjust the tire pressure to the specified range.

## Tire chain

A proper anti-skid chain can damage a vehicle's tires, wheels, suspension, braking system, or body. Only the anti-skid chain approved by XEV new energy vehicles can be used. For more information, please consult XEV new energy vehicles authorized service station. Depending on the location and type of road, regulations for the use of tyre chains may vary. When installing anti-skid chains, comply with local laws and regulations.

### ⚠ ATTENTION

- Do not install unauthorised anti-skid chains, which may damage the brake components..

When installing and removing anti-skid chains, please observe the following precautions

- Anti-skid chain can only be installed on the rear wheel.
- After running 0.5~1 km, tighten the anti-skid chain again, and the speed should not exceed 50km/h.
- Please install the anti-skid chain in strict accordance with the manufacturer's instruction.

### ⚠ ATTENTION

- When using an anti-skid chain, avoid making sharp turns or locking the wheel brakes, which may adversely affect the vehicle's operation.
- When driving a vehicle with antiskid chain, be careful to slow down before entering the turn to avoid losing control of the vehicle, otherwise there will be an accident.

Windwindow washing liquid, scrubber

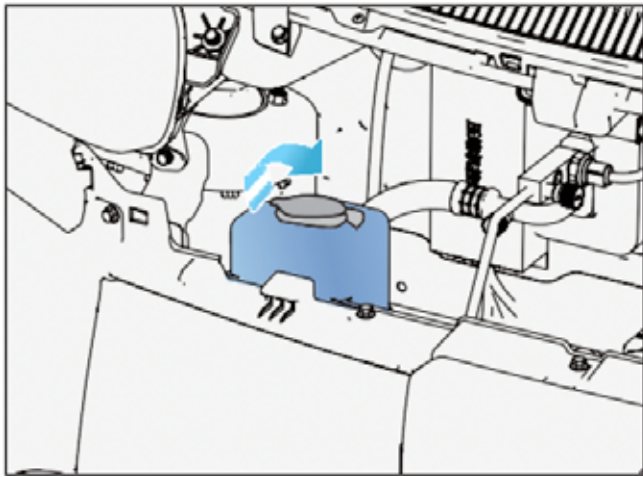

The detergent storage tank is located on the right side of the front cabin to provide the washing liquid for the nozzle of the window scrubber. Please use the detergent recommended and approved for XEV new energy vehicles. Please refer to page P131 for specifications and dosage. Use the scrubber regularly and check whether the scrubber nozzle is smooth and the direction is correct. If the nozzle is clogged, use a needle or thin wire into the hole to clean the blockage. Windwindow scrubber nozzles have been set at the time of production and generally do not need to be adjusted. If adjustments are needed, insert a needle into the nozzle mouth and gently pry to position the nozzle so that the detergent jets directly into the center of the window.

Wiper

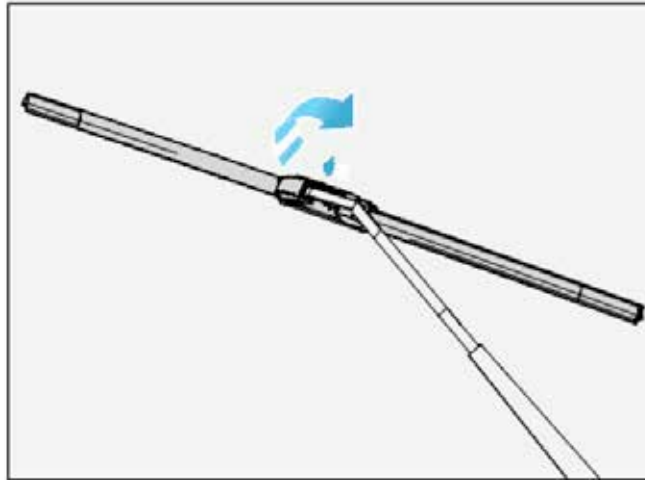

Change of wiper

- Lift the wiper a little.
- Place a rag or equivalent under the wiper arm to prevent the wiper arm from damaging the glass under the action of elastic force.
- Lift the wiper arm, open the wiper clip cover, slowly push the wiper out of the U-hook of the wiper arm, and take out the wiper.
- Lower the wiper arm slowly.
- Install the new wiper blade back to the wiper arm in the reverse procedure. Install the wiper blade and the U hook of the wiper arm in place, close the wiper clip cover.
- Place the wiper arm gently back on the windscreen.

ATTENTION

- Clean the wipers in warm, soapy water and check their condition regularly.
- Frequent cleaning of the windscreen, try to avoid the use of wiper wiper brush sand on the windscreen, so as not to affect the wiper effect and reduce its service life.
- If the wiper is found to be hardened, the wiper scratches on the window, or the wiper does not clean an area, you need to replace the wiper.
- If the wiper or windshield glass is covered with snow and ice or frozen, please clean the snow and ice on the wiper and glass first, then use the wiper, so as not to damage the wiper.
- When changing the wiper, please use the wiper with the same specification as the original wiper.

## Vehicle exterior maintenance

### To wash the car

- Rinse body, wheels and underside of vehicle from top to bottom with plenty of water to remove dirt and dust.
- Use a sponge or cloth to scrub the body.
- Rinse the water.

<b>ATTENZIONE</b>
<ul style="list-style-type: none"> <li>• For dirt that is difficult to remove, wash with soap and rinse with water.</li> <li>• Car body waterproof coating after aging, should be waxed.</li> </ul>

### Automatic station washing

Before entering the auto wash station, fold the rearview mirror. Flush from the front of the vehicle. Unroll the rearview mirror before driving.

<b>ATTENTION</b>
<ul style="list-style-type: none"> <li>• Brushes used for automatic station washing may chafe the surface of the vehicle and damage the finish paint.</li> </ul>

### High pressure washing station

Avoid washing the nozzle too close to the window. Check and make sure the charging port door is closed before washing the car..

### Aluminium wheels

Aluminum wheels should be cleaned with neutral detergent immediately after aluminum wheels adhere to dirt. Rinse aluminum wheels immediately after cleaning them with detergent.

<b>ATTENTION</b>
<ul style="list-style-type: none"> <li>• Use the same neutral detergent and car wax as the paint.</li> <li>• Do not use hard brush for cleaning.</li> <li>• Do not use abrasive cleaners or strong chemical cleaners.</li> <li>• When the wheels are in hot state (such as after a long journey in hot weather), do not use detergent to clean them.</li> </ul>

### Bumper

Do not use abrasive cleaner to scrub the bumper.

<b>WARNING</b>
<ul style="list-style-type: none"> <li>• Turn off the starting switch before washing the car.</li> <li>• When washing the car by hand, we should pay attention to personal safety and guard against being scratched by the edges and corners of the bottom of the vehicle.</li> <li>• Do not flush the electrical parts with water, otherwise it may cause damage or short circuit to the electrical parts.</li> </ul>

**⚠ ATTENTION**

Lavare immediatamente la vettura nelle seguenti circostanze:

- After driving by the sea.
- After driving on the saline road.
- Paint surface with coal tar or resin.
- After the vehicle is driven in the area polluted by coal ash, lampblack, iron powder or on the paint surface.
- Clean exterior lights.
- Do not use organic cleaners or hard brushes to clean, otherwise it may damage the surface of the car lights.
- Do not wax the surface of the car lamp, as the car wax may damage the lampshade.

**Polish with wax**

To protect the paint, wax the outside surface of the vehicle. Before waxing, wash and dry the vehicle. If the paint surface is hot, place the vehicle in a cool place before waxing to cool the paint surface. Polishing is required only if the paint tarnishes or if it adheres to fixed deposits.

Polishing with silicone creates a protective film and does not require waxing. Plastic body parts should not be waxed and polished.

**⚠ ATTENTION**

To protect the finish coat:

- Avoid wiping the surface of the vehicle or wiping it with a hard cloth.
- Do not use steel wool and abrasive detergent to clean the vehicle, so as not to damage the paint surface.
- Wax according to the method of wax coating.

**Glass**

When using soapy water or glass cleaning products to clean the glass, do not let it run onto the body of the car to avoid leaving any marks. Please wipe the glass with a clean cloth to avoid scratches.

**⚠ ATTENTION**

- Do not use hot water to remove snow and ice from the windshield and rearview mirror, or it may cause the glass to burst.
- Do not use corrosive cleaner on the windows.
- Please do not stick stickers on the Windows.

**Vehicle corrosion**

Proper maintenance of vehicles can prevent long-term corrosion of vehicles. The most common causes of vehicle corrosion are: Salts, dust and moisture accumulate in hard-to-reach areas under the vehicle. The paint layer or bottom layer is scratched due to slight impact or by stones and gravel.

If driving in special areas or circumstances, it is important to drive with caution:

- Salt and alkali on roads or dust containing chemical substances will accelerate corrosion. In coastal areas or industrial polluted areas, the air also contains salt.
- High humidity will accelerate corrosion, especially when the temperature is higher than 0.
- Some parts of the vehicle are wet or wet for a long time. Even if other parts are kept dry, they will corrode.
- Indoor high temperature will cause corrosion of some parts due to lack of proper ventilation.
- The above indicates keeping the vehicle as clean as possible, especially the underside of the car, and repairing damaged paint layers as soon as possible.

**To prevent vehicle corrosion, the following guidelines should be observed:**

Regular car washing can keep the body clean, but in order to prevent corrosion, the following points should be observed:

- If you drive on roads containing salt and alkali in winter, or live by the sea, you should wash the walking part of the vehicle at least once a month to reduce corrosion
- High pressure or steam is very effective for cleaning the vehicle chassis and wheel cover, but attention should be paid to the cleaning, should avoid the direct impact of the power battery under the chassis. As it is difficult to see all the mud and dirt in these places, special attention must be paid. Simply wetting mud and debris without removing it will do more harm. Do not allow dust to clog the drain holes of the lower edge of the door, the threshold plate and the parts of the frame, otherwise the accumulation of water in these parts will cause corrosion.

**Check the body paint and trim**

If any fragments or cracks are found on the paint surface, they should be repaired immediately to prevent corrosion.

**Use mudguards**

Use fenders to protect your vehicle when driving in saline areas or on gravel roads. The bigger the fender, the closer it is to the ground, the better.

**Park the vehicle in a fully ventilated garage or roofed place, do not park in a wet, airtight garage**

Washing your car in the garage or driving over water or snow can damp the garage and lead to corrosion. Even if the garage is dry, poor ventilation can corrode a damp vehicle.

### Clean the interior parts

- Use vacuum cleaner to remove dirt and dust on the interior trim parts of the vehicle.
- Wet the rag with lukewarm water, wipe the dirty surface of the interior decoration. If it can not be cleaned, it is necessary to use a special solvent free plastic cleaning agent for cleaning.

<b>WARNING</b>
<ul style="list-style-type: none"> <li>• Do not use detergents containing solvents to clean the surface of the instrument panel. Otherwise, the instrument panel may be damaged.</li> <li>• Do not use polishing wax or polishing detergent. Otherwise, the dashboard may reflect onto the windshield, obstructing the driver's view and causing an accident that can seriously injure or even kill the occupant.</li> </ul>

<b>ATTENTION</b>
<ul style="list-style-type: none"> <li>• Do not soak the cleaning detergent cloth long time placed on the plastic decorations, so as not to cause the plastic decorations fade or crack</li> </ul>

### Clean leather parts

Use vacuum cleaner to remove dirt and dust

- Wet the rag with diluted detergent (please use neutral wool detergent aqueous solution with a diluted concentration of about 5%) and wipe off the dirt and dust left on the leather parts.
- Wring out the rag, and thoroughly wipe off the residual detergent.
- Wipe the residual moisture off the surface with a dry cloth, then let the leather dry in a cool and ventilated place. Improper cleaning of leather trimmings can discolor or stain the leather.

### Leather maintenance

Method: Apply a thin layer of curing agent, and then wipe with a soft cloth..

<b>ATTENTION</b>
<ul style="list-style-type: none"> <li>• Dirty leather trimmings will cause mold. Special care must be taken to avoid oil stains and to keep trim clean at all times.</li> <li>• In hot summer, because the temperature inside the vehicle is easy to rise, it is necessary to avoid placing items made of vinyl plastic or waxy materials on the accessories.</li> <li>• These articles will stick to leather in high temperature. Incorrect cleaning of leather accessories will cause discoloration or spots.</li> </ul>

**⚠ ATTENTION**

- Do not place the washing cloth soaked with detergent on the leather accessories for a long time, so as not to cause the leather to fade or crack.
- Avoid parking the car in the strong sunshine for a long time, so as not to fade the leather. If the car must be parked in the open air for a long time, the leather should be covered to prevent direct sunlight on the leather.
- Do not use solvents (such as gasoline, resin, floor wax, shoe polish and other similar items) to treat leather.
- The use of nylon brush or artificial fiber cloth and other cleaning leather will scrape the good grain on the leather surface.

**Blanket**

Clean the carpet with a good quality foam-type detergent. When cleaning, lather with a sponge or brush and scrub the carpet in a circular motion to clean and dry soiled surfaces.

**⚠ ATTENTION**

- Keep carpets as dry as possible for best results.
- Do not use clean water or add foam type cleaner to the water to clean the carpet.
- Only brush is allowed to clean carpets and floor MATS, do not use brush to clean other fabric surfaces.

## Technical data

<b>Technical data</b> .....	117
Overall dimensions of vehicle .....	117
Technical parameters of vehicle .....	118
Drive motor, reducer technical parameters .....	121
Power battery technical parameters .....	123
Technical parameters of DC/DC switch .....	124
Technical parameters of on-board charger .....	125
Type and dosage of vehicle filling liquid .....	126
The light bulb information .....	127



Overall dimensions of vehicle

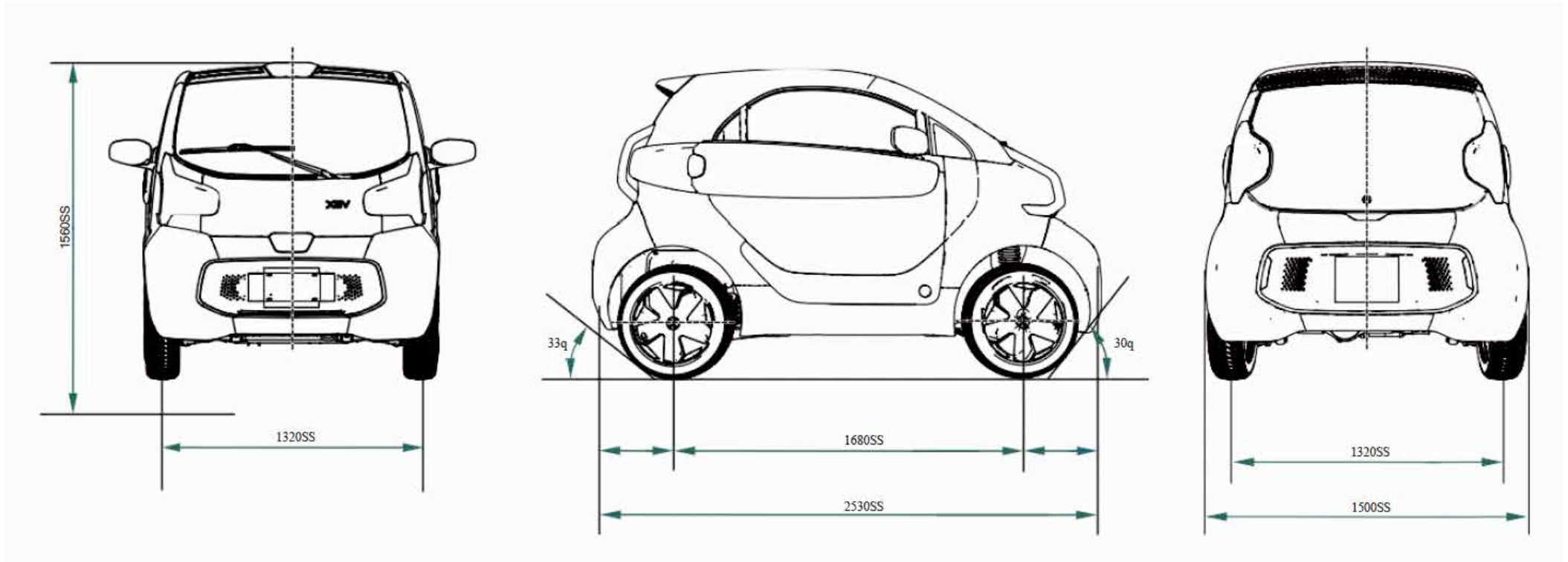

Charging device

Instrument & control devices

Lighting device

Safety device

Vehicle device

Starting & driving

Emergency treatment

Repair & maintenance

Technical information

### Technical parameters of vehicle

Model		Y01/Y01-H	
Overall dimensions	length x width x height (mm)	2530×1500×1560	
wheel track	front (mm)	1320	
	rear (mm)	1320	
wheelbase (mm)		1680	
front suspension (mm)		430	
rear suspension (mm)		420	
approach angle (°) (no load)		30	
departure angle (°) (no load)		33	
Minimum ground clearance - full load (mm)		132	
the tyre information	Tyre Size	155/65R14 155/60R15	
	front tyre pressure (kPa)	220 (no load)	230 (full load)
	front tyre pressure (kPa)	220 (no load)	230 (full load)

Model		Y01/Y01-H
Unladen mass (kg)		449 (without batteries)
Maximum permissible mass (kg)		774
wheel nut torque (N m)		120±10 N m
Max speed (km/h)		70
Max driving mileage (km)		150
Minimum Diameter of turning circle (mm)		7000
brake type		Four wheel disc brake
parking brake type		foot brake
front wheel	toe-in (')	0-2 mm
	Camber angle	0,1°
	caster angle	3,7°
	Kingpin inclination angle	13,2°
Note: the tyres installed on a motor vehicle must be of the same specifications made in one factory, and the unbalance is allowed to be no more than 0.5% of the weight of the tyre.		

Model	Y01/Y01-H
drive type	Rear-engine Rear-drive
number of passengers	2
Maximum load mass for front/rear axle (kg)	306/451
Front/rear axle load (kg)	217/265
maximum gradability (%)	20
0km/h-50km/h acceleration time (s)	≤8
Max. exterior noise in accelerating driving (dB(A))	≤70
Max. interior noise when vehicle moves at a constant speed (dB(A))	≤64
brake distance (70 km/h full load) (m)	20
Brake pedal free travel (mm)	≤5
Energy consumption (kWh)	7,4
front suspension/rear suspension	McPherson type independent suspension/towed arm type non-independent suspension
charging time (h)	5-7

Drive motor, reducer technical parameters

Type of drive motor system	Permanent magnet synnchronous model H021A
rated power (kW)	7,5
Max. power (kW)	13
rated voltage (VDC)	72
scope of input voltage (VDC)	60-90
peak current (A/RMS)	450 (30 s)
rated torque (N m)	20,5
peak torque (N m)	≥90
rated speed (rpm)	3500
Max. speed (rpm)	7000
auxiliary voltage (V)	/
peak efficiency (%)	92
insulation resistance (MΩ)	20

Type of drive motor system	Permanent magnet synchronous / model H021A
noise (dB (A))	≤70
leak current (mA)	≤10
Electronically controlled storage ambient temperature (°C)	-40~85
Electronic control of working environment temperature (°C)	-30~55
insulation grade	H
cooling mode (raffreddamento)	Natural air cooling
protection level	IP67 (motor)/IP66(Motor Controller)
overall dimensions (mm)	306*198*198 (motor)
mass (kg)	29 (motor)/8,6 (motor controller)
Total speed ratio of rear-drive reducer	8:1

### Technical parameters of the power battery

Tipo di cella	litio-ferro-fosfato
battery changing mode	fast battery changing
total quantity	1x3 connection in series
total weight (kg)	125
single Ah	135 Ah
single Ah	3x8=24
Ah per singola unità	135 Ah
total voltage / capacity (V/Ah)	72 V/10,37
cycling life	≥2500 times (capacity ≥ 80% initial capacity)
protection level	IP67

### DC/DC Switcher technical parameters

rated output power (W)	600
rated input voltage (V)	72
input voltage range (V)	54-90
output voltage (V)	13,5±0,3
efficiency	85%
operating ambient temperature	-25 °C - 50 °C
Working environment humidity	5-95%



### Technical parameters of on-board charger

rated output power	2,2 kW
Input Voltage Range	90-270 VAC
Input Current	≤13 A
input frequency	45-65 Hz
output voltage	72 V
rated output current	25A
communication mode	CAN
oveall efficiency	≥93%
power factor	≥0,99

Type and dosage of vehicle filling liquid

N.	filling items	filling capacity	filling specification
1	reducer lubricating oil	1 L	85W/90/GL-4
2	windscreen washing liquid	1,3 L±20 mL	/
3	Air conditioning refrigerant	450±10 mm	R-134a
4	synthetic brake fluid	L-H between (240±10 mm)	DOT4

Bulb information

bulb		colour	power (W)	quantity (pezzi)	
exterior	front combination light	driving beam light H7-12V-55W	white	55	2
		passing beam light H7-12V-55W	white	14	2 (LED)
		front clearance light	white	4	2
		front turning light	amber	21	2
	rear combination light	brake light	red	5,6	2 (LED)
		reversing light	white	21	2
		rear clearance light	red	5,6	2 (LED)
		rear turning light	amber	21	2
	luce della targa		white	0,6	2 (LED)
interior	roof light C-12V-5W	white		2	



X  
YOYO

XEV  
BORN FOR CHANGE